

FASTCOM[®] ADAPTERS

FASTCOM[®]: IG422/1-PCI

**Fully Isolated Single Channel RS-422/RS485 Interface
for PCI Bus**

Hardware Reference Manual



COMMTECH, INC.
9011 E 37th St N
Wichita KS USA
67226-2006





COMMTECH

9011 E. 37TH STREET N.
WICHITA, KANSAS 67226-2006

(316) 636-1131

FAX (316) 636-1163

<http://www.commtech-fastcom.com/>

COPYRIGHT (C) 1999, 2002, 2003, 2010

All rights reserved, including those to reproduce this document or parts thereof in any form without permission in writing from Commtech, Inc.

FASTCOM and the "Alpha Lemur" are registered trademarks of Commtech, Inc.

IBM is a registered trademark of International Business Machines Corporation.

Microsoft is a registered trademark of Microsoft Corporation.

WINDOWS is a trademark of Microsoft Corporation.





REVISION NOTES

<u>REVISION</u>	<u>PAGE NUMBER</u>	<u>CHANGES MADE</u>
2.1	14	Changed warranty to 2 years
2.2	6	Added link to installation manual
2.3	12	Updated contact information
2.4	8,9	Updated Fastcom Serial Settings
2.5	1	Updated revision level
	13	Changed warranty period to lifetime
2.6	13	Changed warranty to limited lifetime



CONTENTS

- [“CE” CERTIFICATE](#) 1

- INTRODUCTION
 - [Description / Block Diagram](#) 3
 - [Specifications / Features](#) 4
 - [Board Layout](#) 5

- INSTALLATION
 - [Installing the Hardware / Software](#) 6
 - [Testing the Installation](#) 6

- [FASTCOM SERIAL SETTINGS](#) 8

- [DB9 PIN DESCRIPTION](#) 10

- [RS-422/485](#) 11
 - [Termination Resistance](#) 12

- [TECHNICAL SUPPORT](#) 13

- APPENDIX A
 - [16C850 UART Technical Data](#) 14





EUROPEAN UNION DECLARATION OF CONFORMITY

Information Technology Equipment

The Company COMMTECH, INC. declares under its own and full responsibility that the product

" Fastcom: IG422/1-PCI - Revision 1.1 "

on which is attached this Certificate is compliant to the "89/336/EEC" Directive, amended by 92/31/EEC and 93/88/EEC.

[] The product identified above complies with the requirements of the above EU Directive by meeting the following standards:

- EN 50081-1 (1992) EMC Generic Emission Standard - Part 1, Residential, Commercial and Light Industry
 - EN 55022 (1995), CISPR 22 (1993) Limits and Methods of Measurement of Radio Disturbance Characteristics of Information Technology Equipment, 30 MHz - 1 GHz, Class B Limits
- EN 50082-1 (1992) EMC Generic Immunity Standard - Part 1, Residential, Commercial and Light Industry
 - IEC 801-2 (1984), Method of Evaluating Susceptibility to Electrostatic Discharge, Level 4
 - IEC 801-3 (1984), Radiated Electromagnetic field Requirements, Level 3
 - IEC 801-4 (1988), Electrical Fast Transient/Burst Requirements, Level 2

Products listed on this declaration are exempt from the requirements of the 73/23/EEC directive due to the input voltage specification as stated in Article 1 of the directive.

The technical documentation required to demonstrate that this product meets the requirements of the EMC Directive has been compiled by the signatory below and is available for inspection by the relevant enforcement authorities.

In WICHITA, KS on April 11th of 2003

COMMTECHTM
COMMUNICATION • TECHNOLOGIES

9011 E. 37th Street North
Wichita, KS 67226-2006
(316) 636-1131
Fax (316) 636-1163

Glen R. Alvis

Mr. Glen R. Alvis
Chief Engineer

CE



INTRODUCTION

The new Fastcom: IG422/1-PCI adapter is one of the fastest, most advanced isolated ground single-channel RS-422/485 adapter in the industry. Primarily designed for commercial, industrial, and OEM applications, the Fastcom: IG422/1-PCI **features one RS-422/485 channel. All signals, including Ground, are fully isolated from your computer's power supply and bus.**

The advanced universal asynchronous receiver and transmitter (UART) chip used on the Fastcom: IG422/1-PCI is fully register-compatible with standard 16C550 UARTs, but **provides extraordinary 128 byte FIFOs for receive and transmit buffering.** This buffering is extremely valuable when working with RS-422/485 communications within high-overhead operating systems such as Windows NT and Windows 98.

Other "isolated" RS-422/RS-485 adapters provide only partial isolation for the signal lines, leaving your system susceptible to voltage surges, ground faults, and ground loops. Power surges and ground loop errors will destroy common RS-422 adapters. More importantly, these conditions will destroy your PC, adapters in it, and hard and floppy disk drives, plus present an electric shock hazard to system operators. The *full isolation* of RS-422/RS-485 signal lines *and Ground* provided by the Fastcom: IG422/1-PCI is extremely important to any industrial/commercial application that requires high reliability, data integrity, and system safety. The Fastcom: IG422/1-PCI is designed to provide full isolation from a remote RS-422/RS-485 device: the UART is isolated from the RS-422/RS-485 signals and the Ground is isolated from the power supply and chassis of the PC.

Software drivers for Windows 95, Windows 98, and Windows NT are supplied. Multiple Fastcom: IG422/1-PCI adapters can be installed in all three operating systems.

The Fastcom RS-422-PCI family also includes the two-channel Fastcom: 422/2-PCI and the four-channel Fastcom: 422/4-PCI. ISA bus versions are also available.

The following is the basic structure of the Fastcom: IG422/1-PCI:

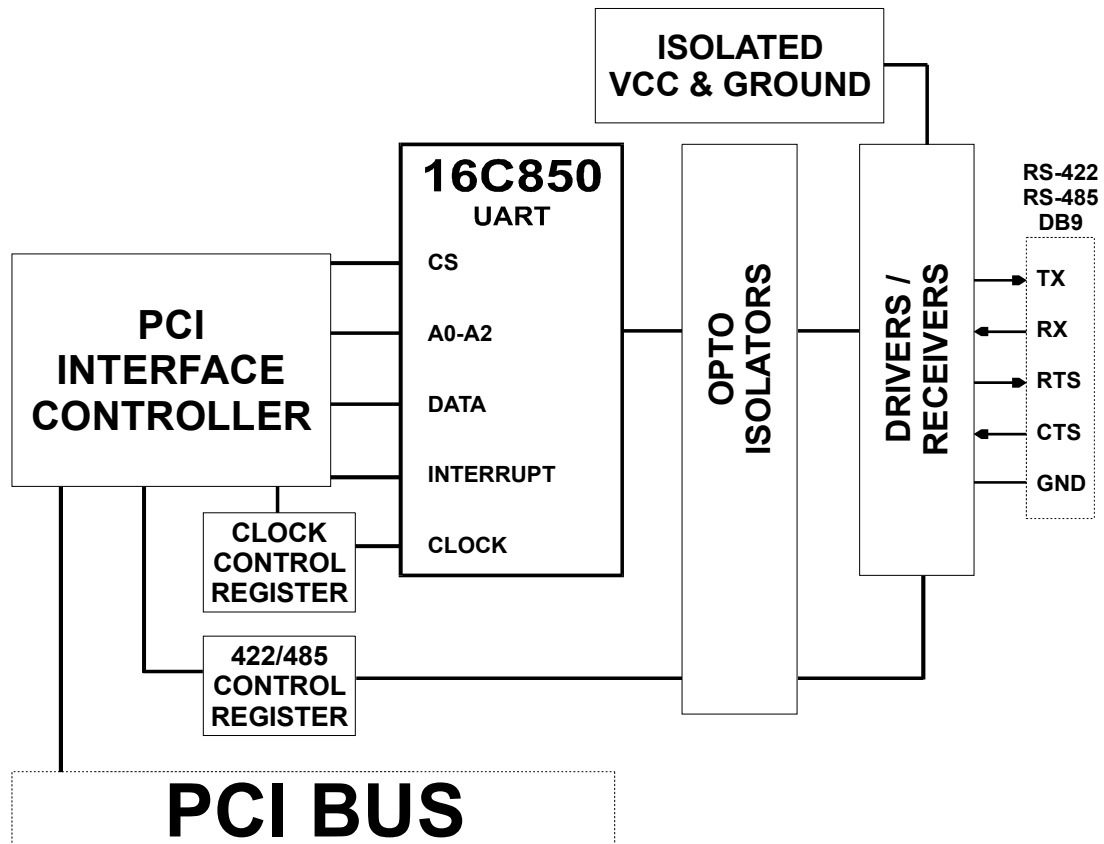

SPECIFICATIONS:

UART	16C850	
BAUD RANGE	All standard PC baud rates up to 115.2 Kpbs	
BUFFERING	Transmit - 128 bytes Receive - 128 bytes	
INTERFACE	RS-422 / RS-485 TX, RX, RTS, CTS	
BUS	PCI	
POWER REQUIREMENTS:	+5	600mA (Typical)
ADDRESS REQUIREMENTS:	PCI Controller	128 bytes
	UART	8 bytes
	Control Registers	4 bytes
INTERRUPT REQUIREMENTS:	1 (per board)	

FEATURES:

Isolation

3000 Volt Opto Isolator breakdown
2000 Volt transformer breakdown
Ground isolated from power supply and chassis

New high performance 16C850 UART

Standard on the Fastcom: IG422/1-PCI, *no extra charge*
All standard PC baud rates up to 115.2 Kbps
128 byte FIFOs for *improved throughput*

User programmable baud rate

“Switchless” design

Hardware control for 485 driver

“Echo cancel” available in 485 mode

Comprehensive Hardware and Software Documentation

Made in Wichita, Kansas, U.S.A.

FASTCOM: IG422/1-PCI

BOARD LAYOUT

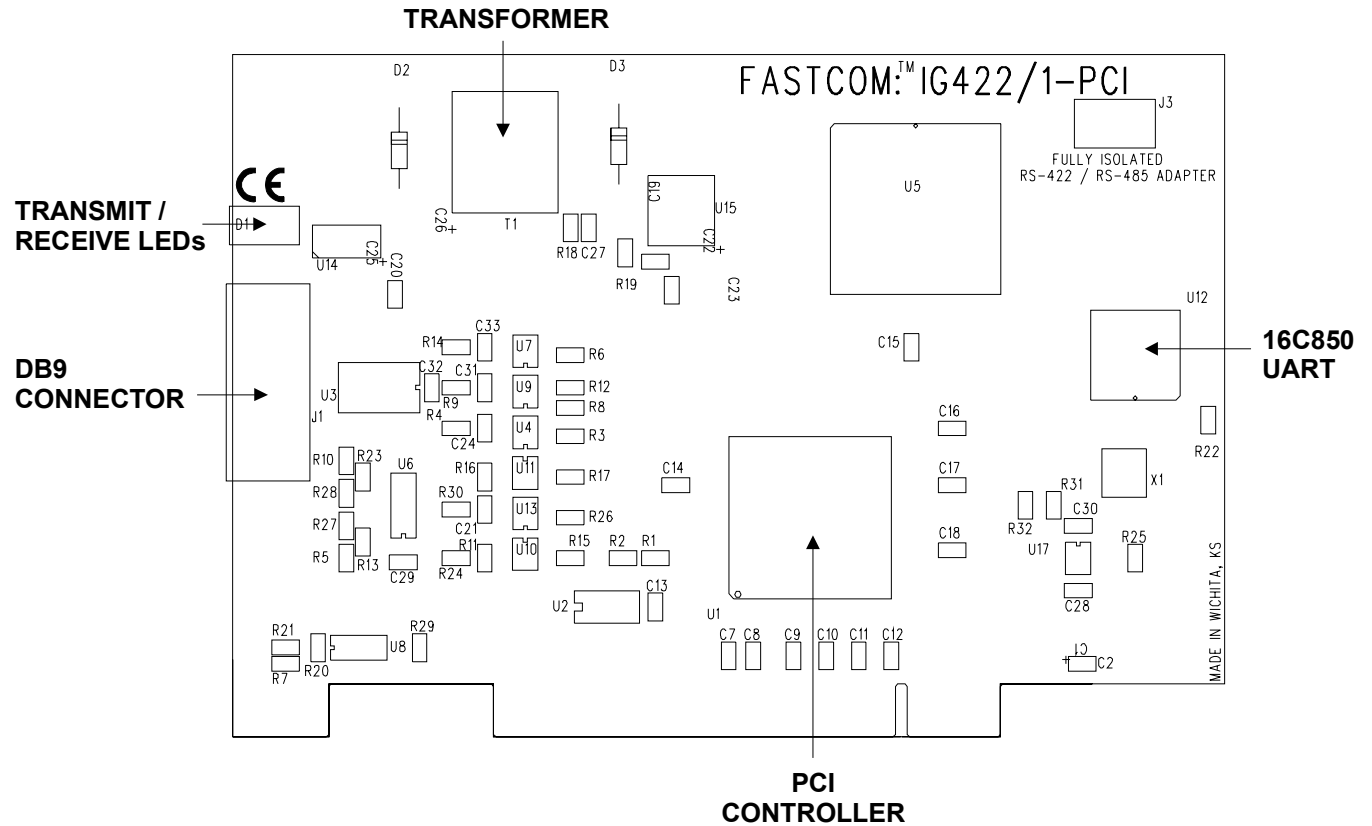

PACKING LIST

FASTCOM: IG422/1-PCI CARD
FASTCOM CD

If an omission has been made, please call technical support for a replacement.

HARDWARE INSTALLATION

Important: Observe Electrostatic Discharge (ESD) precautions when handling the Fastcom: IG422/1-PCI board.

1. Unpack the Fastcom: IG422/1-PCI. Keep the box and static bag for warranty repair returns.
2. Select an open PCI slot in your PC.
3. After removing the blank bracket from your PC, install the Fastcom: IG422/1-PCI in the PC by pressing it firmly into the slot. Install the bracket screw to hold it firmly in place.
4. Re-install the cover on your PC.

SOFTWARE INSTALLATION

Select the link above to open the Installation Manual. Under Fastcom – Async-PCI series cards, select your operating system and follow the instructions. When you are finished, select Fastcom: IG422/1-PCI from the list at the end of the Fastcom – Async-PCI series cards section to return to this manual.

TESTING THE INSTALLATION

To fully test the installation of your Fastcom: IG422/1-PCI, you will need to build a "loop back plug". Materials needed are a DB9 male plug, solder cup style, and two short pieces of 20 or 24 AWG stranded wire. This loop back plug can be used to test any RS-422 port. Jumper the pins together on the DB9 as illustrated below:

- | | |
|---|-----|
| 4 | TX+ |
| 5 | TX- |
| 8 | RX+ |
| 9 | RX- |

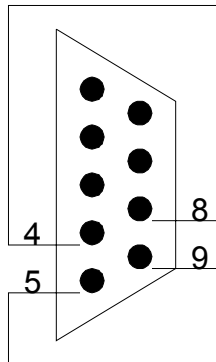

TESTING YOUR FASTCOM ASYNC PCI PORT IN WINDOWS

These instructions assume that you have already installed the card and have followed the installation instructions. The SERIALGT.EXE program (98, NT) or the Device Manager (2K, XP) should show the boards/ports that are installed, and the COM numbers assigned to those ports.

1. Install the loopback plug on the port to test.
2. Find and run the TTY example program (simple terminal).
From the Start menu, choose Run, browse to and select D:\Fastcom_disks\AsyncPCI\tty\tty2.exe.
Click the Open button.

Click the OK button to run the program.

3. With the TTY program running, select Settings from the menu.
Select the COM port number that has the loopback plug on it.
Uncheck all of the flow control checkboxes (DTR/DSR, RTS/CTS, XON/XOFF).
Click OK.
From the TTY Main menu select Action, then Connect.
4. At this point you should get a blinking cursor in the upper left corner (under the menu bar).
5. You should be able to type on the keyboard and see the letters that you type on the screen. If you see what you are typing, then your port is installed and operating properly.

If you do not get to the blinking cursor stage, but rather encounter a "Connection Failed" message box, some possible causes are:

1. In NT, if multiple ports are opened (running more than one instance of TTY), the ports are using the same IRQ, and the PermitShare registry entry is 0, the second port to be opened will fail. Use the registry editor and expand HKEY_LOCAL_MACHINE ->SYSTEM ->CurrentControlSet ->Services ->Serial, change the PermitShare value from 0 to 1, reboot, and run the test again.
2. The interrupt that was selected by the plug-and-play bios is trying to be shared with another device that is not configured to share the IRQ (either Device or Driver Exclusive IRQ setting). Try a different PCI slot or disable the other offending device.
3. IRQ steering is enabled on Windows 98 and Windows is not assigning an IRQ to the Fastcom card. Try disabling IRQ steering or varying the options in Control Panel ->System ->Device Manager ->System Devices ->PCI Bus.
4. Multiple COMx assignments. In Windows NT, the driver setup assumes that there are not any ports installed above COM4, and starts assigning the Fastcom ports at COM5. If there is already a COM5 (or higher) in the system, it is likely that the Fastcom ports are being assigned to the same port name(s). Run the SERIALGT.EXE program (D:\Fastcom_disks\AsyncPCI\nt\serialgt.exe for Windows NT, D:\Fastcom_disks\AsyncPCI\95\serialgt.exe for Windows95) and re-assign the com port numbers to these ports to be different than any other ports in the system.

If you get to the blinking cursor stage, but do not see what you type with the loopback installed, some possible reasons are:

1. Incorrect/faulty loopback construction or a bad connection.
2. The port is setup to have RS-485 enabled and the "RX Echo Disable" checkbox is checked. If the RX Echo Disable is checked you will be unable to run a simple loopback test, as the purpose of the echo disable is to strip the characters that are sent/received at the same time. Uncheck the RX Echo disable, reboot, and try the test again.
3. The RTS/CTS flow control is checked and there is not a RTS->CTS loopback or the CTS disabled checkbox was unchecked. If you enable flow control, you must allow CTS to be active in order for the driver to transmit data. Either disable flow control or wire the RTS->CTS (and possibly DTR->DSR) loops and try the test again.
4. The loopback plug is not on the correct port/cable.

FASTCOM SERIAL SETTINGS

These settings can be accessed using the application serialgt.exe (Win98/NT) or in the Fastcom Serial Settings tab of the Fastcom AsyncPCI Communications Port Properties dialog (Win2k/XP), which is found in the device manager under Ports (COM & LPT).

CLOCK/4

Clock divisors of 1 and 4 are available. Clearing the checkbox selects a divisor of 1 and setting the checkbox selects a divisor of 4. It is best to leave this box unchecked.

Auto 485

When checked, OUT1 of the UART becomes a 485 driver control signal, enabling automatic tri-state control. You must check 485 Enable and uncheck Enable Source for this to work.

RX Trigger

Determines the number of bytes that will be stored in the receive FIFO on the 16C850 before an interrupt is triggered. Valid values are from 1 to 128 bytes. The optimal setting is 64 bytes. For 16C550 compatibility, set to 8.

TX Trigger

Determines the number of bytes remaining in the transmit FIFO on the 16C850 before an interrupt is triggered. Valid values are from 0 to 127 bytes. The optimal setting is 64 bytes. For 16C550 compatibility, set to 0.

TX Write Size

Determines the number of bytes sent to the board at a time. Valid values are from 1 to 128. This number plus the TX Trigger value should not exceed 128. The optimal value is 64. For 16C550 compatibility, set to 16 or 1.

CTS Disable

When checked, the CTS signal is forced active, ignoring the signal from the connector. When unchecked, the CTS signal is read from the connector.

485 Enable

When checked, the 485 driver mechanism is enabled.

RX Echo Disable

When checked, the receive is disabled during transmit.

Enable Source

- When checked, the 485 driver control is RTS. This is compatible with older boards and software which are not automatically controlled by hardware. Uncheck Auto 485.
- When unchecked, the 485 driver control is OUT1 on the UART. This is compatible with hardware control of automatic 485 mode. Check Auto 485.

BaudTable (Win2K/XP)

This table represents the standard baud rates that the Fastcom card will currently support. If you wish to use a non-standard baud, you may enter it into one of the boxes on the table and hit the tab key (**do not hit enter**, hitting enter will exit the program). This will set the onboard clock generator to a frequency (see Input Frequency below) that will divide down to the new baud rate. The rest of the table will also be updated to reflect other bauds that can be used with the calculated clock frequency. If you wish to return to the standard rates, you can set the top box to 115200 and hit tab and the rest of the bauds will be filled in.

Note: The baud rates that you set will not be available to standard Windows applications like HyperTerminal. The new rates will be available to you in your code or in applications that allow user defined baud rates such

as TTY2, which can be found on the Fastcom disk (Fastcom_CD\Fastcom_disks\AsyncPCI\tty\tty2.exe).

THIS SETTING=THIS BITRATE (Baud Rate Substitution Table) (Win 98/NT)

Under THIS SETTING you will see the standard PC baud rates, from 115.2K to 300. If you wish to use a baud rate not shown, type the baud rate in the box next to 115200 (e.g., type 128K as 128000), and hit the tab key. **Do not hit enter.** Hitting enter will exit the program. If the baud rate changes after you tab, move to the next box down and try again. Continue moving down until the baud rate stays the way you want it. Now note the standard PC baud rate to the left of the box you ended on. You will select this standard baud rate to set up your com ports, and the baud rate you require will be substituted. If you receive an error message stating that the maximum baud rate was exceeded, change the Clock Divisor to 1 and try again.

INPUT FREQUENCY

This is the calculated frequency required to generate the baud rate requested. When you click OK on the Fastcom Serial Settings page, this frequency is sent to the clock generator and the new baud rates will be available.

DB9 PIN DESCRIPTION

The FASTCOM: IG422/1-PCI features one RS-422/RS-485 channel, which is accessed through a DB9 connector on the board.

The following is a pin description of the DB9 connector:

PIN NO.	SIGNAL NAME	DIRECTION
1	SIGNAL GROUND (GND)	GROUND
2	READY TO SEND + (RTS+)	OUTPUT
3	READY TO SEND – (RTS-)	OUTPUT
4	TRANSMIT DATA + (TX+)	OUTPUT
5	TRANSMIT DATA – (TX-)	OUTPUT
6	CLEAR TO SEND – (CTS-)	INPUT
7	CLEAR TO SEND + (CTS+)	INPUT
8	RECEIVE DATA + (RX+)	INPUT
9	RECEIVE DATA – (RX-)	INPUT

RS-422/RS485

Most engineers have worked with RS-232 devices at least once in their career. If you have never worked with RS-422 or RS-485 devices, you will be pleased to know that working with the FASTCOM: IG422/1-PCI is not much different from working with an RS-232 device.

The RS-422 standard was developed to correct some of the deficiencies of RS-232. In commercial and industrial applications, RS-232 has some significant problems. First, the cable length between RS-232 devices must be short (usually less than 50 feet at 9600 baud). Second, many RS-232 errors are the result of cables picking up normal industrial electrical noises such as fluorescent lights, motors, transformers, and other EMF sources. Third, RS-232 data rates are functionally limited to 19.2K Baud. On the other hand, the newer RS-422 standard makes cable lengths up to 5000 feet possible and is highly immune to most industrial noises. Data rates are also improved -- the FASTCOM: IG422/1-PCI features **all** standard PC baud rates. These improvements were made possible by differentially driving and receiving the data as opposed to the single ended method employed by the RS-232 standard. With the RS-422 standard, the transmit signal (TX in RS-232) is a differential signal consisting of TX+ and TX-; the receive signal (RX in RS-232) consists of RX+ and RX-.

Another draw back of RS-232 is that more than two devices cannot share a single cable. This is also true of RS-422, and that's why the RS-485 standard was developed. RS-485 offers all of the benefits of RS-422 and also allows multiple units (up to 32) to share the same "twisted pair" of wires (see diagram on next page). RS-485 is often referred to as a "multi-drop" or "two-wire, half duplex" network. In order for an RS-485 system to work, only one driver (transmitter) can occupy the network at a time. This means that each station on the network must control the enabling/disabling of their drivers in order to avoid network conflicts. If two drivers engage the network at the same time, data from both will be corrupted. In RS-485 mode, the receivers are always enabled.

For a more detailed description of RS-422 and RS-485, we recommend the following references:

LINEAR AND INTERFACE CIRCUITS APPLICATIONS, Volume 2: Line Circuits, Display Drivers. By D.E. Pippenger and E. J. Tobaben. Published 1985 by Texas Instruments. ISBN-0-89512-185-9

Note: This book may be difficult to find in a bookstore. The best place to get it is directly from Texas Instruments or from one their component dealers. Publication # SLYA002.

"Driver/Receiver Family Extends Data-Link Performance", ELECTRONIC PRODUCTS, January 15, 1985. By Dale Pippenger and Joe Miller

TERMINATION RESISTANCE

In both the RS-422 and the RS-485 mode, the receiver end of the cable between two stations must be terminated with a resistor equal to the characteristic impedance of the wire. This is to prevent signal reflections in the wire and to improve noise rejection. However, **you do not need to add a terminator resistor to your cables when you use the Fastcom: IG422/1-PCI. The termination resistance is built in.** We have installed a terminator resistor for the receiver: between RX+ and RX- and between CTS+ and CTS-.

If you are using the Fastcom: IG422/1-PCI in a multi-drop network, the termination resistor should be removed from all units except the first and last (see the RS-485 illustration below). Call for technical support if you need to modify the resistor. You may also order the Fastcom: IG422/1-PCI without the termination resistor installed (it is easier to add the resistor than to remove it). Observe the resistors in the following drawings and remember that they are built into the Fastcom: IG422/1-PCI (shown below):

Typical RS-422 Installation

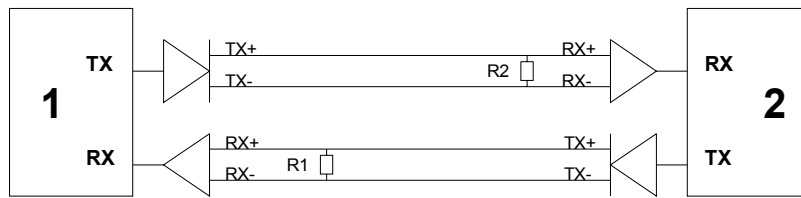

R1 & R2 - Line Termination (100 ohms)

Typical RS-485 Installation

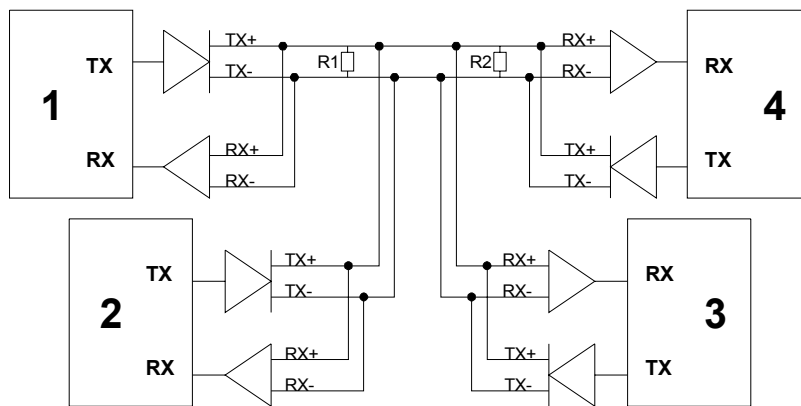

R1 & R2 - Line Termination (100 ohms)

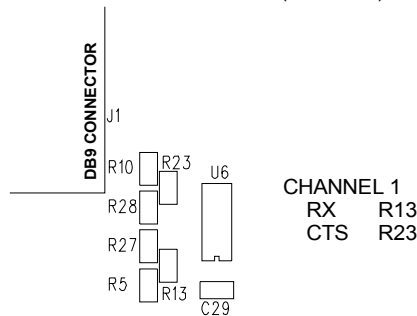

TECHNICAL SUPPORT

Commtech provides extensive technical support and application suggestions. Most of the problems that occur with the FASTCOM: IG422/1-PCI can be corrected by double-checking the switch positions, your cables and your program. We recommend that you build the loop back plug that is described in the Programming section of this manual. With that plug, you can quickly isolate the problem to the board, cables, or software.

If you still have unresolved questions, use the following procedure to get technical support:

1. Call our Technical Support Staff at (316) 636-1131. They are on duty from 9:00 AM to 5:00 PM Central Time.
2. Ask for technical support for the FASTCOM: IG422/1-PCI. Be ready to describe the problem, your computer system, your application, and your software.
3. If necessary, our staff will give you an RMA number (Return Material Authorization). Use this number on the mailing label and in all references to your board. Put the board back in its static bag and in its box. Ship the board back to us as directed.
4. If you prefer, you may FAX a description of the problem to us at (316) 636-1163, or we can be reached on the Internet at "<http://www.commtech-fastcom.com/TechSupport.html>" or by email at "techsupport@commtech-fastcom.com".

FASTCOM LIMITED LIFETIME WARRANTY

Commtech's entire FASTCOM product line is covered by a limited lifetime warranty against defects in workmanship. This warranty is available only to the original purchaser and only covers defects in our workmanship. Any FASTCOM board that is returned to Commtech will, at the option of Commtech, be repaired or replaced at no charge -- except for circumstances excluded by this warranty.

A Return Materials Authorization (RMA) number must be obtained from Commtech before a return will be accepted. Please contact us via telephone or email to obtain an RMA number.

You are responsible for shipping charges when you return a FASTCOM board to Commtech. We will pay the shipping charges to send the board back to you if a defect in workmanship is found. However, if no defect in workmanship is found, or the board is not found to be defective, or the any of the following warranty exclusions occur, you will be responsible for shipping charges both ways.

Warranty Exclusions

This warranty does not cover problems or damage resulting from, but not limited to, the following:

1. Any modification, misuse, abuse, disassembly, misapplication, or unauthorized repair by anyone other than Commtech.
2. Any improper operation, including any use not in accordance with any verbal product instructions or documentation.
3. Connection to an improper voltage supply or ESD damage.
4. Any other cause not related to workmanship.

Non-Warranty Repairs

We can provide a quote for non-warranty repairs upon request.

If any Commtech product is damaged such that it cannot be repaired, you can return it to Commtech for replacement under our *Non-Repairable Replacement* policy, regardless of the cause of damage. Commtech will replace the unit at 60% of the then-current list price.

Limitation of Liability

Commtech shall not be liable for any special, incidental, indirect, or consequential damages whatsoever, including but not limited to loss of profits, revenue, or data (whether direct or indirect), or commercial loss for breach of any express or implied warranty on your product even if Commtech has been advised previously of the possibility of such damages. Commtech's liability, in any case, shall not exceed the original product purchase price.



APPENDIX A

16C850

UART DATA

