

FASTCOM[®] ADAPTERS

SUPERFASTCOM-cPCI

**Four Channel High Speed Synchronous Serial Interface
for Compact PCI Bus
Hardware Reference Manual**

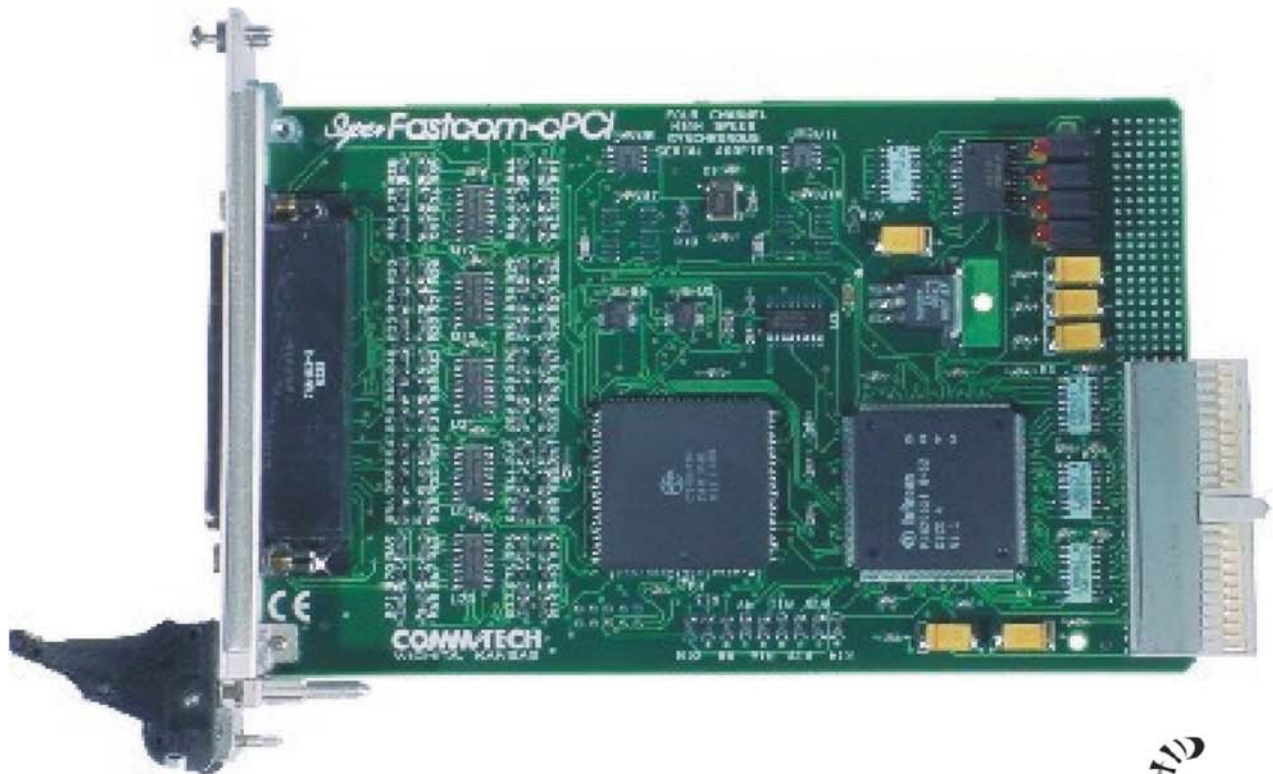

COMM-TECH, INC.

**9011 E 37th St N
Wichita KS USA
67226-2006**





COMMTECH

9011 E. 37TH STREET N.
WICHITA, KANSAS 67226-2006

(316) 636-1131

FAX (316) 636-1163

<http://www.commtech-fastcom.com/>

COPYRIGHT (C) 2003, 2004, 2005, 2006, 2010

All rights reserved, including those to reproduce this document or parts thereof in any form without permission in writing from Commtech, Inc.

FASTCOM and the "Alpha Lemur" are registered trademarks of Commtech, Inc.

Microsoft is a registered trademark of Microsoft Corporation.
WINDOWS is a trademark of Microsoft Corporation.





REVISION NOTES

<u>REVISION</u>	<u>PAGE NUMBER</u>	<u>CHANGES MADE</u>
1.0	All	Document created 4/3/03
1.1	15	Changed warranty period to lifetime
1.2	7	Corrected pin designations for channel one
1.3	9-10	Added more programs to list
1.4	14-15	Added "Errata" section
1.5	8	Modified Hardware Installation section, repaginated after page 8
1.6	All	Modified SuperFastcom manual to create SuperFastcom-cPCI manual
1.7	11	Added local bus register description
1.8	9	Fixed setfreq.exe command
1.9	19	Changed warranty to limited lifetime

Table of Contents

INTRODUCTION	1
SPECIFICATIONS	2
FEATURES	2
BOARD LAYOUT	3
COMMUNICATIONS OVERVIEW	4
PROTOCOL SUPPORT	5
GENERAL	5
SUPERFASTCOM-CPCI / ESCC FAMILY COMPARISON	5
ENHANCEMENTS TO THE ESCC SERIAL CORE	5
SIMPLIFICATIONS OF THE ESCC SERIAL CORE.....	5
SUPERFASTCOM CPCI CABLE ASSEMBLY	6
SUPERFASTCOM CPCI DB25 CABLE CONNECTOR DESCRIPTION	7
INSTALLATION	8
HARDWARE INSTALLATION	8
SOFTWARE INSTALLATION.....	8
TESTING THE INSTALLATION	8
WINDOWS 2000 TEST PROCEDURE.....	9
SOFTWARE UTILITIES	9
PROGRAMMING	11
MEMORY MANAGEMENT	13
ERRATA	15
RS-422 / RS-485	17
TERMINATION RESISTANCE	18
TECHNICAL SUPPORT	19
APPENDIX A	20
INFINEON 20534 TECHNICAL DATA.....	20



INTRODUCTION

The new *SuperFASTCOM-cPCI* Compact PCI adapter is a synchronous, high-speed, four channel serial communications adapter designed for Windows and LINUX based industrial & commercial systems. Its outstanding features include data rates up to 40 Mbps and the ability to buffer up to 4 Gigabytes of data (Windows 2000) in system memory. This CompactPCI serial adapter is designed to fit most 3U chassis.

The *SuperFASTCOM-cPCI* supports standard synchronous protocols (HDLC, SDLC) and their variations, as well as standard asynchronous data formats. The board features on board line termination as well as high-speed RS-422 drivers/receivers that allow all baud rates up to 40 Mbps. The **on-board clock generator** provides a high-speed clock source for your system, eliminating the need for a separate external clock.

Programming is simplified with the inclusion of drivers, example programs and comprehensive documentation supplied on the Fastcom CD. The *SuperFASTCOM-cPCI* provides high speed and high reliability while greatly reducing development time and system complexity.

The *SuperFASTCOM* family includes:

Form Factor	Line Type	Ports
PCI	RS422/485 OR RS232	4
PC/104+	RS422/485	1 or 2
CompactPCI	RS422/485	4
CompactPCI Rear IO	RS422/485	4

The following diagram illustrates the basic structure of the *SuperFASTCOM-cPCI*:

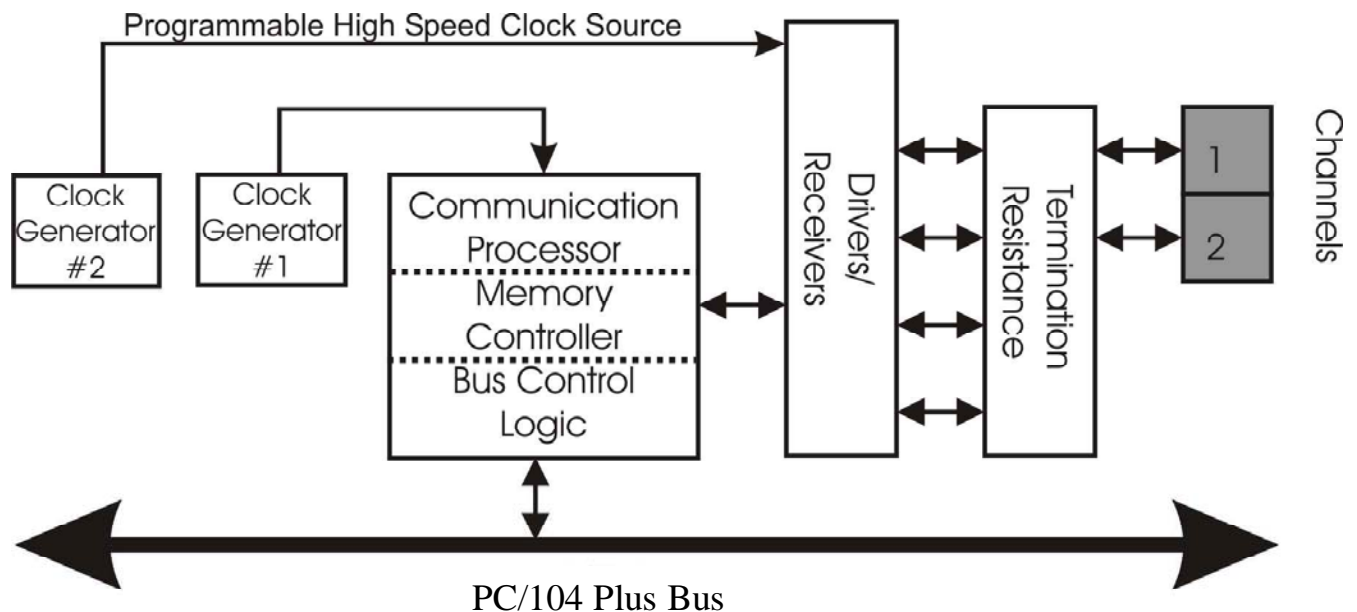

Specifications

Communications Controller:	Infineon 20534
OS Support:	Linux, Windows XP, 2000, NT4
Data Rate:	All baud rates up to 40 Mbps
Data Buffering:	Up to 4 GB (Window) Up to 52 Mbytes per channel (Linux)
Drivers/Receivers:	High Speed RS-422/485
Signals:	TxD, RxD, RTS, CTS, DCD, TT, RT, ST
Connector Configuration:	DB-78 to four DB-25 connectors
Bus Interface:	Compact PCI (cPCI)
Power Requirements:	450mA @ +5V (typical)
Environment	
Operating Temperature Range:	-0°C to 70°C
Humidity:	0 to 90% (non-condensing)
Mean Time Between Failure:	24.61 Years

Features

- Four independent channels
- Two programmable on-board clock generators
- Advanced Infineon controller chip
- Hardware documentation and software included on CD
- Made in Wichita, KS U.S.A.

Board Layout

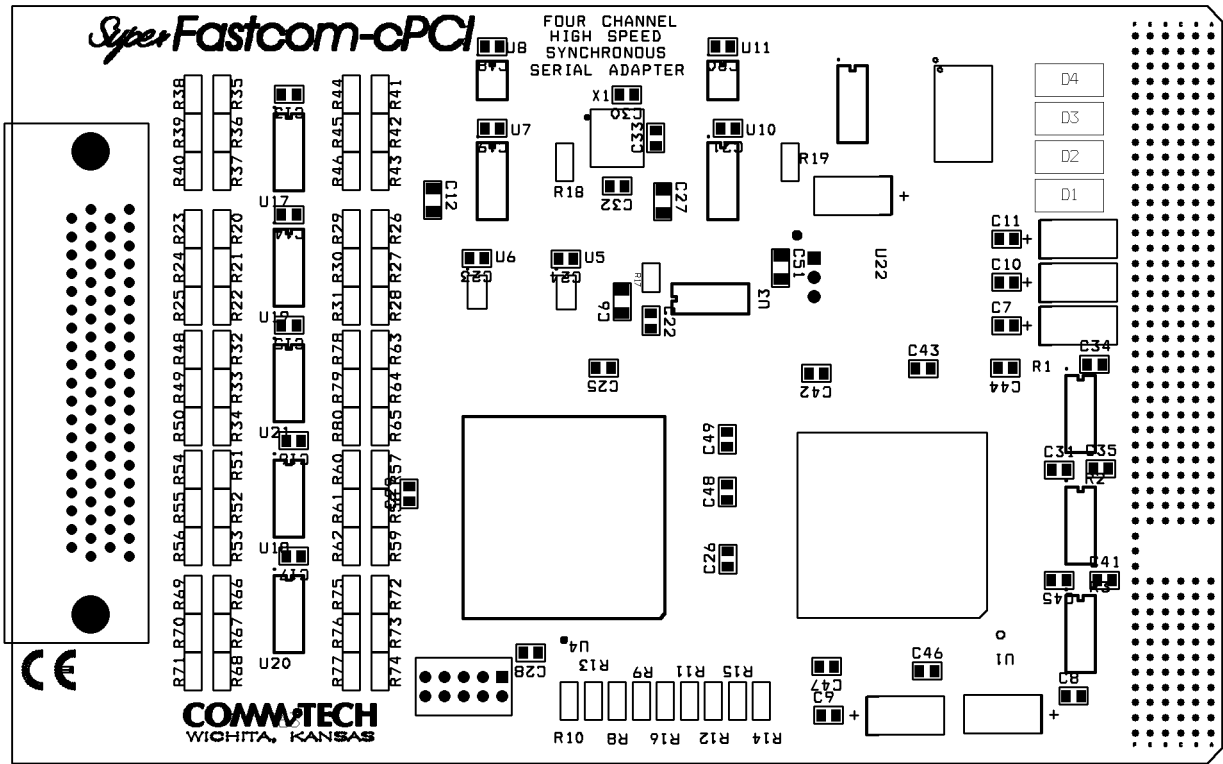

Top of board

Packing List

SuperFASTCOM-cPCI Card
 FASTCOM CD

If an omission has been made, please call customer support for a replacement.

COMMUNICATIONS OVERVIEW

- HDLC/SDLC Protocol Modes
 - Automatic flag detection and transmission
 - Shared opening and closing flag
 - Generation of inter-frame time fill '1's or flags
 - Detection of receive line status
 - Zero bit insertion and deletion
 - CRC generation and checking (CRC-CCITT or CRC-32)
 - Transparent CRC option per channel and/or per frame
 - Programmable Preamble (8 bit) with selectable repetition rate
 - Error detection (abort, long frame, CRC error, short frames)
- Bit Synchronous PPP Mode
 - Bit-oriented transmission of HDLC frame (flag, data, CRC, flag)
 - Zero bit insertion/deletion
 - 15 consecutive '1' bits aborts sequence
- Octet Synchronous PPP Mode
 - Octet-oriented transmission of HDLC frame (flag, data, CRC, flag)
 - Programmable character map of 32 hard-wired characters (00 H -1F H)
 - Four programmable characters for additional mapping
 - Insertion/deletion of control-escape character (7D H) for mapped characters
- Asynchronous (ASYNC) Protocol Mode
 - Selectable character length (5 to 8 bits)
 - Even, odd, forced or no parity generation/checking
 - 1 or 2 stop bits
 - Break detection/generation
 - In-band flow control by XON/XOFF
 - Immediate character insertion
 - Termination character detection for end of block identification
 - Time out detection
 - Error detection (parity error, framing error)
- BISYNC Protocol Mode
 - Programmable 6/8-bit SYN pattern (MONOSYNC)
 - Programmable 12/16-bit SYN pattern (BISYNC)
 - Selectable character length (5 to 8 bits)
 - Even, odd, forced or no parity generation/checking
 - Generation of inter-frame time fill '1's or SYN characters
 - CRC generation (CRC-16 or CRC-CCITT)
 - Transparent CRC option per channel and/or per frame
 - Programmable Preamble (8 bit) with selectable repetition rate
 - Termination character detection for end of block identification
 - Error detection (parity error, framing error)
- Extended Transparent Mode
 - Fully bit transparent (no framing, no bit manipulation)
 - Octet-aligned transmission and reception
- Protocol and Mode Independent
 - Data bit inversion
 - Data overflow and under run detection
 - Timer

Protocol Support

- Address Recognition Modes
 - Mode 0 - No address recognition
 - Mode 1 - 8-bit (high byte) address recognition
 - Non-Auto Mode - 8-bit (low byte) or 16-bit (high and low byte) address recognition

General

- On-chip Rx and Tx data buffer (the buffer size is 128 32-bit words each)
- Programmable transmit buffer size per channel; receive buffer allocation on request.
- Programmable watermark for receive channels to control transfer of receive data to host memory.
- Two programmable watermarks for each transmit channel, i.e. one controlling data loading from host memory and one controlling transfer of transmit data to the corresponding Serial Communication Controller (SCC).
- Internal test loop capability.

***Super*FASTCOM-cPCI / ESCC FAMILY COMPARISON**

Enhancements to the ESCC Serial Core

The *Super*FASTCOM-cPCI adapter contains the core logic of the ESCC2 V3.2A as the heart of the device. Some enhancements are incorporated in the *Super*FASTCOM-cPCI. These are:

- Octet and Bit Synchronous PPP protocol support as in Internet RFC-1662
- 16-Kbyte packet length byte counter
- Enhanced address filtering (16-bit maskable)
- Enhanced time slot assigner

Simplifications of the ESCC Serial Core

The following features of the ESCC core have been removed:

- SDLC Loop mode
- Extended transparent mode 0 (this mode provided octet buffered data reception without usage of FIFOs; the *Super*FASTCOM-cPCI supports octet buffered reception via appropriate threshold configurations for the SCC receive FIFOs)

SuperFASTCOM cPCI CABLE ASSEMBLY

The cable provided with your SuperFASTCOM cPCI adapter splits each channel from the DB78 to into four DB 25 male connectors.

<u>SIGNAL</u>	<u>DB25 PIN #</u>	<u>DB78 PIN NUMBER</u>			
		<u>CHANNEL 1</u>	<u>CHANNEL 2</u>	<u>CHANNEL 3</u>	<u>CHANNEL 4</u>
GND	1	58	38	9	48
GND	7	68	29	10	49
SD-	2	70	13	22	62
SD+	14	50	32	2	46
RD-	3	73	36	6	65
RD+	16	53	17	26	42
RTS-	4	71	33	3	63
RTS+	19	51	14	23	45
CTS-	5	74	18	27	66
CTS+	13	54	37	7	41
DCD-	10	76	31	8	40
DCD+	8	57	12	28	60
TT-	11	69	30	1	61
TT+	24	52	11	21	47
RT-	9	72	16	25	64
RT+	17	56	35	5	43
ST-	12	75	34	4	67
ST+	15	55	15	24	44
PRGCLK-	23	77	N/A	N/A	N/A
PRGCLK+	20	78	N/A	N/A	N/A

SuperFASTCOM cPCI DB25 CABLE CONNECTOR DESCRIPTION

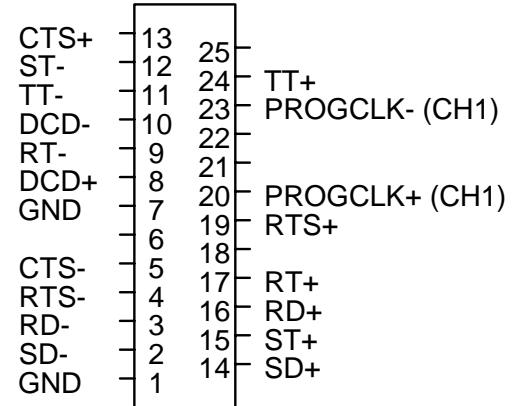

PIN DESCRIPTIONS

<u>PIN#</u>	<u>DESCRIPTION</u>	<u>422 TYPE</u>	<u>CONNECTED TO</u>
1	SHIELD/GROUND		GND
7	SIGNAL/GROUND		GND
2	TRANSMIT DATA	A	SD-
14	TRANSMIT DATA	B	SD+
3	RECEIVE DATA	A	RD-
16	RECEIVE DATA	B	RD+
4	REQUEST TO SEND	A	RTS-
19	REQUEST TO SEND	B	RTS+
5	CLEAR TO SEND	A	CTS-
13	CLEAR TO SEND	B	CTS+

CLOCK SIGNALS

<u>PIN#</u>	<u>DESCRIPTION</u>	<u>422 TYPE</u>	<u>CONNECTED TO</u>
8	DATA CARRIER DETECT	A	DCD+
10	DATA CARRIER DETECT	B	DCD-
24	TRANSMIT CLOCK OUT	A	TT+
11	TRANSMIT CLOCK OUT	B	TT-
17	RECEIVE CLOCK IN	A	RT+
9	RECEIVE CLOCK IN	B	RT-
15	TRANSMIT CLOCK IN	A	ST+
12	TRANSMIT CLOCK IN	B	ST-

Special Signals On Cable 1 Only

Pin 20 PROGCLK + Programmable clock output
Pin 23 PROGCLK-

INSTALLATION

Hardware Installation

Important: Observe Electrostatic Discharge (ESD) precautions when handling the *SuperFASTCOM-cPCI* board.

1. Remove the cover from your computer.
2. Unpack the *SuperFASTCOM-cPCI* adapter. Keep the box and static bag for warranty/repair returns.
3. Select a free slot in your 3u cPCI chassis.
4. Install the *SuperFASTCOM-cPCI* in the chassis by pressing it firmly into the connector. Install the bracket screws to hold it firmly in place
5. Install the *SuperFASTCOM* cPCI cable.

Software Installation

Select the link above to open the Installation Manual. Under *SuperFASTCOM*, select your operating system and follow the instructions. When you are finished, select *SuperFASTCOM-cPCI* from the list at the end of the *SuperFASTCOM* section to return to this manual.

TESTING THE INSTALLATION

To fully test the installation of your SuperFastcom, you will need to build a "loop back plug". Materials needed are a DB25 female receptacle (solder cup style) and a few short pieces of 20 or 24 AWG stranded wire. Jumper the pins together on the DB25 as illustrated:

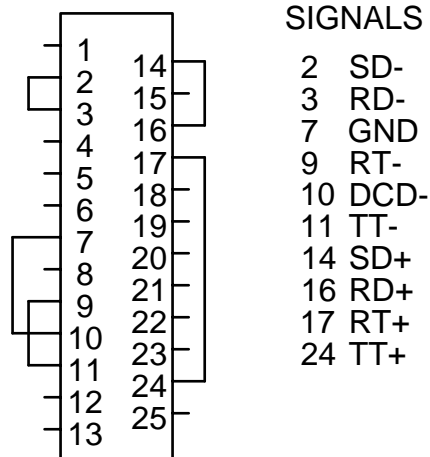

Windows 2000 Test Procedure

1. Place the loop back plug onto the 40-pin connector.
2. Open a console/DOS window.
3. Change directories to where you installed/copied the software.
4. Execute: setfreq 0 1000000 0
5. Execute: sfcset 0 hdlcset
6. Execute: loopback 0 h

Wait a few moments; press a key, and the errors/number of bytes sent through the loop will be displayed. The numbers will vary depending on how long you allow the test to run.

Executing the following sequence can then check the remaining ports

1. sfcset 1 hdlcset
2. loopback 1 h
3. sfcset 2 hdlcset
4. loopback 2 h
5. sfcset 3 hdlcset
6. loopback 3 h

SOFTWARE UTILITIES

These programs and their source can be found on the Fastcom CD or downloaded from our website at <http://www.commtech-fastcom.com/>. They are meant to be used as educational tools and programming references when designing your own software.

- sfcset.exe use to change register settings in conjunction with the hdlcset file
- hdlcset, asyncset, bisyncset generic settings files to be used with sfcset.exe
- getclock.exe returns programmable clock #1 rate (osc)
- getclock2.exe returns programmable clock #2 rate (progclk +/-)
- setclock.exe sets the programmable clock #1 (osc)
- setclock2.exe sets the programmable clock #2 (prograckl +/-)
- loopback.exe user program to effect a loopback on a SuperFastcom channel
- sfcmf.exe
 - Install your loopback plug onto the SuperFastcom.
 - Run "sfcmf.exe".
 - Select "connect" from the menu.
 - A dialog will open. Select the port to use (0,1,2,3).
 - Click on "OK".
 - An info box will open; click "OK".
 - Type a message: "Hello, world".
 - What you type should show up under "Transmit" in the window.
 - Select "Send" from the menu.
 - The message will appear in red under "Received".
 - To open a different port, either select "File->New" or "Disconnect" from the menu.
- readlb.exe user program to read a SuperFastcom special register
- writelb.exe user program to read a SuperFastcom special register

- readreg.exe user program to read a 20534 register
- writereg.exe user program to write to a 20534 register
- send.exe user program that opens a file and sends it through port 0
- flushrx.exe user program to flush the SuperFASTCOM receiver/buffers
- flushtx.exe user program to flush the SuperFASTCOM transmitter/buffers
- getbufs.exe user program to get buffering/descriptor parameters for a port
- setbufs.exe user program to set buffering/descriptor parameters for a port
- getclock.exe user program to get the current clock generator settings
- getclock2.exe user program to get the current program clock generator settings
- read_file_hdlc.exe user program to read hdlc frames from a port and stuff them to a file
- sendfile.exe user program to send a file out a SuperFastcom port
- setchecktimeout.exe user mode function to set the timeout timer in the driver that checks for frames to be returned or sent
- setfs6131clock.exe user program that sets the fs6131 clock generator which is only valid if you have an extended temperature card with fs6131's on it
- setrfi.exe user program to mask/unmask the frame end interrupt indication for receive descriptors
- setrirq.exe user program to set the interrupt rate for receive descriptors
- settirq.exe user program to set the interrupt rate for transmit descriptors
- settfi.exe user program to mask/unmask the frame end interrupt indication for transmit descriptors
- simuln200.exe user program to generate 26 byte hdlc frames simulating an LN200
- st_tt.exe user program to switch the onboard txclk multiplexer between the TT output and the ST input
- status.exe user program to read status from a SuperFastcom port

PROGRAMMING

Refer to the enclosed FASTCOM CD for example programs, product updates, and software for testing your installation. Refer to the Infineon PEF 20534 User's Manual for register information.

Local Bus Interface for PEF 20534 - Byte accesses

Register at offset 0

Channel 1		Channel 2	
Bit 0	1 = receive constantly enabled 0 = receive enabled only when RTS is off	Bit 4	1 = receive constantly enabled 0 = receive enabled only when RTS is off
Bit 1	1 = transmit constantly enabled 0 = transmit enabled only when RTS is on	Bit 5	1 = transmit constantly enabled 0 = transmit enabled only when RTS is on
Bit 2	1 = TT constantly enabled 0 = TT enabled only when RTS is on	Bit 6	1 = TT constantly enabled 0 = TT enabled only when RTS is on
Bit 3	No function	Bit 7	No function

Register at offset 1 = No function

Channel 3		Channel 4	
Bit 0	1 = receive constantly enabled 0 = receive enabled only when RTS is off	Bit 4	1 = receive constantly enabled 0 = receive enabled only when RTS is off
Bit 1	1 = transmit constantly enabled 0 = transmit enabled only when RTS is on	Bit 5	1 = transmit constantly enabled 0 = transmit enabled only when RTS is on
Bit 2	1 = TT constantly enabled 0 = TT enabled only when RTS is on	Bit 6	1 = TT constantly enabled 0 = TT enabled only when RTS is on
Bit 3	No function	Bit 7	No function

Register at offset 2

Channel 1		Channel 3	
Bit 0	0 = ST connected to TXCLK 1 = ST not connected	Bit 4	0 = ST connected to TXCLK 1 = ST not connected
Bit 1	0 = TT connected to TXCLK 1 = TT not connected	Bit 5	0 = TT connected to TXCLK 1 = TT not connected
Channel 2		Channel 4	
Bit 2	0 = ST connected to TXCLK 1 = ST not connected	Bit 6	0 = ST connected to TXCLK 1 = ST not connected
Bit 3	0 = TT connected to TXCLK 1 = TT not connected	Bit 7	0 = TT connected to TXCLK 1 = TT not connected

Offset 0 & 1 – These bits are generally for choosing between 422 and 485 communications.

- Receive constantly enabled – (default) for RS-422 communication
- Receive enabled only when RTS is off – also Rx Echo Cancel; disables the receiver when transmitting so that you do not receive everything that you transmit when using 2-wire RS-485.
- Transmit constantly enabled – (default) for RS-422 communication
- Transmit enabled only when RTS is on – turns off the transmitter when it is not actively sending data so that it does not contend with another transmitter on the data bus
- TT constantly enabled – (default) for RS-422 communications

- TT enabled only when RTS is on – turns off the transmit clock when it is not actively sending data so that it does not contend with another transmitter on the clock bus

Offset 2 – These bits are for setting the transmit clock direction. The PEB20534 has only one transmit clock pin that can be an input or an output using CCR0:TOE. If that pin is configured to be an output, then it must be connected to a line driver. If that pin is configured to be an input, then it must be connected to a line receiver. The ST pin is TxClk as an input and the TT pin is TxClk as an output.

- ST connected to TxClk – TxClk connected to the ST input pin. **Never set CCR0:TOE=1 when setting this bit!**
- ST not connected to TxClk – (default) TxClk not connected to the ST input pin
- TT connected to TxClk – (default) TxClk connected to the TT output pin
- TT not connected to TxClk – TxClk not connected to the TT output pin.

Note: It is possible to configure the TxClk pin as an input TOE=0, and connect it to both the TT and ST pins. This will allow the external clock from the ST pins to be outputted on the TT pins.

MEMORY MANAGEMENT

High-speed communications requires that large amounts of transmitted/received data be buffered so as to prevent data loss and maintain data throughput. The *SuperFASTCOM-cPCI* is designed to utilize system memory directly, bypassing the system processor. The *SuperFASTCOM-cPCI* accesses system memory through high-speed PCI Bus Mastering, using its on-board bus master controller and supplied software. This procedure for direct memory access (DMA) is by far the fastest, most efficient method of handling the large amounts of data that high-speed communications generates. Data is transferred to and from the *SuperFASTCOM-cPCI* adapter at data bus speed. Buffering a high-speed data stream is critical in order to maintain data integrity and reliability, to avoid data loss, and to prevent data overrun. The *SuperFASTCOM-cPCI* does all this with minimal system processor involvement; therefore there is no reduction in processor performance due to data communication overhead.

How it works - The user designates in his program how much system memory will be allocated to communications: the more memory in your system, the more you can allocate to the communication process. As data is received, the on-board communication processor fills a small local buffer. When this is full, the bus master controller on the *SuperFASTCOM-cPCI* transfers this data directly to system memory. The local buffer is reset and the process begins again. Transmitting data works in reverse; data from system memory is directly transferred to the local buffer on the *SuperFASTCOM-cPCI*. When the local buffer is empty, new data from memory is directly transferred in. All of this occurs without slowing or interfering with the system processor.

The high speed PCI Bus Mastering procedure for direct memory access provides the fastest, most efficient method of data transfer. It also improves efficiency and reduces the cost of the *SuperFASTCOM-cPCI* board by eliminating the need for on-board memory or a processor.

PROGRAMMABLE CLOCK GENERATORS

The *SuperFASTCOM-cPCI* features two Programmable Clock Generators. Each is an AMI FS6131 chip, which offers a fully user-programmable phase-locked loop clock pulse generator in a single 16-pin package. The output of the generator may be changed "on the fly" to any desired frequency value. The ability to dynamically change the output frequency adds a whole new degree of freedom for the designer.

Why have two clock generators?

The first clock generator (the **OSC** clock generator) provides the clock pulse to the PEF20534 communications processor chip. Its maximum frequency is 33MHz. The second clock generator (the **PROGCLK** clock generator) directly drives the PROGCLK+ and PROGCLK- output signals (PIN 20 and 23 on Cable #1). The PROGCLK has a maximum frequency of 40MHz. The PROGCLK is designed to provide a system wide high-speed clock pulse.

[Click here for additional information on the AMI FS6131.](#)

An important fact about the clock generator

There is only one clock input line on the PEF 20534 communications chip and it is connected to the **OSC** clock generator on the *SuperFASTCOM-cPCI* board. The **OSC** clock generator can be programmed from any channel (SFC0, SFC1) but you are programming the same clock generator (the OSC clock generator) in each case. Just keep in mind that the baud rate generators are independent for each channel, but both baud rate generators are fed from one clock source (the OSC clock generator). If you change the OSC clock generator rate you will change the input to the baud rate generators for both channels.

If you have multiple baud rates that must be generated on multiple channels, you should select an OSC clock rate from which all of the required baud rates can be derived. *Changing the OSC clock generator output will affect the baud rates of all channels!!!!*

ERRATA

The errata listed below are known issues with the either Superfastcom board or the PEB20534 controller itself. For more information regarding any of these issues, please contact Commtech [technical support](#).

- **Serial Bus Configuration Timing Modes**

The SuperFastcom was not designed to make use of Serial Bus Configuration timing modes 1 and 2. Do not attempt to configure CCR0:SC(2..0) to use these modes as they will not work correctly.

- **Maximum Value of Baudrate Generator**

The maximum value 'BRM' in register BRR must not exceed $M = 14$ (the specified maximum value is $M = 15$). This limits the baud rate generator unit to frequency division factors in the range $k = 1 \dots 1,048,576$, instead of $k = 1 \dots 2,097,152$.

- **DPLL Algorithm for FM0, FM1 and Manchester Encoding**

Recovering the clock from an FM0-, FM1- or Manchester-encoded receive data stream using the DPLL circuitry is not working. The DPLL-asynchronous interrupt (PLLA) occurs continuously.

- **HDLC Mode: False Receive Status Byte**

The receive status byte RSTA belonging to an already received frame is overwritten by 0x00 if the following two conditions are met:

The interframe timefill number of '1' bits between the closing flag and the opening flag of the next frame is in the range of [1 - 5].

The receive CRC checking mode is selected to transfer the receive CRC into the receive FIFO (CCR2:RCRC = '1').

In all cases meeting the first condition, the number of '1' bits is treated as an invalid HDLC frame. This frame is prevented from being reported or forwarded to the receive FIFO because of its invalid length. However the serial receive logic calculates a receive status byte RSTA = 0x00 (invalid frame).

If the receive CRC is selected to be transferred to the receive FIFO (second condition), the receive status value of the previous valid frame is not yet transferred when calculating the invalid receive status byte. Thus the original receive status value is overwritten by 0x00 marking the previous frame as 'invalid'.

Workaround: The error cannot occur if bit CCR2:RCRC is set to '0', i.e. receive CRC is not transferred to the receive FIFO. Otherwise (if CCR2:RCRC = '1') reception of less than 6 consecutive '1' bits as interframe timefill must be avoided. This can be achieved by the transmitter either selecting interframe timefill flag sequences or preamble transmission.

- **HDLC Mode: Transmission with Shared Flags**

If the shared flag option is enabled in HDLC mode via bit CCR1:SFLAG, the first byte of a frame might be replaced by a '7E' flag or 'FF' octet on the transmit line, depending on the interframe time fill selection (bit CCR2:ITF). This leads to a damaged transmit frame.

Workaround: It is recommended to disable shared flag transmission by setting bit CCR1:SFLAG = '0'.

Note: Reception of frames with shared flags is always possible and neither affected by this erratum nor by setting of bit CCR1:SFLAG. Thus networking with other HDLC equipment supporting shared flags is not restricted.

- **Asynchronous PPP Mode: Reception**

In asynchronous PPP mode the SCC receiver expects a back-to-back stream of ASYNC characters. Once synchronized on the first ASYNC character the receiver expects further octets back-to-back in a fixed scheme determined by the (8, N, 1) character format. The receiver does not synchronize again on subsequent ASYNC characters.

Workaround: Do not attempt to configure ASYNC PPP mode, to realize asynchronous PPP mode it is recommended to configure the SCC in ASYNC mode, implementing CRC calculation and character mapping in software. Examples for fast CRC calculation and the character mapping specification are given in RFC 1662 (July 1994) document.

- **Extended Transparent Mode: Minimum Frame Length**

If the frame length in extended transparent mode is programmed to one, an XDU interrupt is generated with all its consequences (transmit SCC stops).

Workaround: Frame lengths of 2 or more bytes should be used instead. If a 1-byte frame shall be sent, an idle character should be attached to it.

- **HDLC Automode: Full-duplex Operation**

In HDLC Automode the transmission of an I-frame might be spoiled by simultaneous reception of a frame, sometimes resulting in endless repetition of a byte or in failure of the responding S-frame. Then this channel does not respond autonomously to further reception events.

Workaround: None. Do not use full-duplex Automode.

- **Command Execution (CEC) Status Bit Error With External Clocking**

In general the PEB20534 supports external clock gapping in any clock mode in which the internal transmit or receive clock is supplied via the dedicated RxClk and/or TxClk pins. If one of the clocks is externally gapped, the respective receive or transmit block remains in its current static condition until the clock signal is active again. Any command bit in register CMDR (e.g. 'XRES' and 'RRES') effects either the transmit or receive logic and command execution only depends on this block and its clock supply respectively. Nevertheless all commands are forwarded to both transmit and receive block and command execution must be reported internally by both blocks to reset status bit STAR:CEC. Another command is only accepted if 'CEC' bit is cleared.

Example: The SCC is configured in clock mode 0a, a clock signal is provided at pin TxClk but pin RxClk is supplied with a constant value (no clock signal or gapped). A transmitter reset command applied by write access to register CMDR will be executed by the transmit block, but status bit 'CEC' remains active afterwards, because the receive block cannot report command execution without clock supply. Any further command will be ignored while 'CEC' bit is active.

Workaround: Transmit and receive blocks must be supplied with clock signals in general. Because reset of the command execution (CEC) status bit might be delayed due to one of the clocks temporarily gapped, 'CEC' status bit must be checked for '0' before writing a command bit.

- **Carrier Auto-detect in HDLC Mode**

The carrier detect (CD) input pin is supposed to enable and disable reception in clock modes 0, 2, 3, 6 and 7. In HDLC/PPP mode this function is not working properly and thus should not be enabled with bit CCR1:CAS.

- **Receiver in Extended Transparent Mode Does Not Initialize**

When attempting to use Extended Transparent Mode (raw bits), it appears as though the receiver does not activate. It unclear whether this is a bug in the PEB20534 or whether it was done by design, but the port that will be receiving in Ext. Trans. Mode must be initialized in clock mode 1 with a clock present on the RT pins. It can then be switched to any other clock mode and will operate correctly.

Workaround: If your configuration already uses an external receive clock, simply initialize the card in clock mode 1 (CCR0:CM2..CM0 = '001') with a clock present on the RT pins and then change to whatever clock mode you wish to use. If you do not have an external clock, you can utilize the PROGCLK output pins that are located on the DB25 connector for port 1 at pins 20 and 23. Jumper the PROGCLK pins to the RT pins of your receiving port and initialize the card in clock mode 1.

RS-422 / RS-485

Most engineers have worked with RS-232 devices at least once in their career. If you have never worked with RS-422 or RS-485 devices, you will be pleased to know that working with the SuperFASTCOM-cPCI is not much different from working with an RS-232 device.

The RS-422 standard was developed to correct some of the deficiencies of RS-232. In commercial and industrial applications, RS-232 has some significant problems. First, the cable length between RS-232 devices must be short (usually less than 50 feet at 9600 Baud). Second, many RS-232 errors are the result of cables picking up normal industrial electrical noises such as fluorescent lights, motors, transformers, and other EMF sources. Third, RS-232 data rates are functionally limited to 19.2K Baud. On the other hand, the newer RS-422 standard makes cable lengths up to 5000 feet possible and is highly immune to most industrial noises. Data rates are also improved -- the SuperFASTCOM-cPCI features data rates up to 10 Mbps. These improvements were made possible by differentially driving and receiving the data as opposed to the single ended method employed by the RS-232 standard. With the RS-422 standard, the transmit signal (TX in RS-232) is a differential signal consisting of SD+ and SD-; the receive signal (RX in RS-232) consists of RD+ and RD-.

Another draw back of RS-232 is that more than two devices cannot share a single cable. This is also true of RS-422, and that's why the RS-485 standard was developed. RS-485 offers all of the benefits of RS-422 and also allows multiple units (up to 32) to share the same twisted pair. RS-485 is often referred to as a "multi-drop" or "two-wire, half duplex" network because the drivers (transmitters) and receivers share the same two lines. In fact, up to 32 stations can share the same "twisted pair". In order for an RS-485 system to work, only one driver (transmitter) can occupy the network at a time. This means that each station on the network must control the enabling/disabling of their drivers in order to avoid network conflicts. If two drivers engage the network at the same time, data from both will be corrupted. In RS-485 mode, the receivers are always enabled.

For a more detailed description of RS-422 and RS-485, we recommend the following references:

LINEAR AND INTERFACE CIRCUITS APPLICATIONS, Volume 2: Line Circuits, Display Drivers. By D.E. Pippenger and E. J. Tobaben. Published 1985 by Texas Instruments. ISBN-0-89512-185-9

Note: This book may be difficult to find in a bookstore. The best place to get it is directly from Texas Instruments or from one their component dealers. Publication # SLYA002.

"Driver/Receiver Family Extends Data-Link Performance", ELECTRONIC PRODUCTS, January 15, 1985. By Dale Pippenger and Joe Miller

Termination Resistance

In both the RS-422 and the RS-485 mode, the receiver end of the cable between two stations must be terminated with a resistor equal to the characteristic impedance of the wire. This is to prevent signal reflections in the wire and to improve noise rejection. However, **you do not need to add a terminator resistor to your cables when you use the SuperFASTCOM-cPCI. The termination resistance is built in.** We have installed a terminator resistor for each receiver: between each RD+ and RD- and between CTS+ and CTS- for each channel.

If you are using the SuperFASTCOM-cPCI in a multi-drop network, the termination resistor should be removed from all units except the first and last (see the RS-485 illustration below). Call for technical support if you need to modify the resistor. You may also order the SuperFASTCOM-cPCI without the termination resistor installed (it is easier to add the resistor than to remove it). Observe the resistors in the following drawings and remember that they are built into the SuperFASTCOM-cPCI:

Typical RS-422

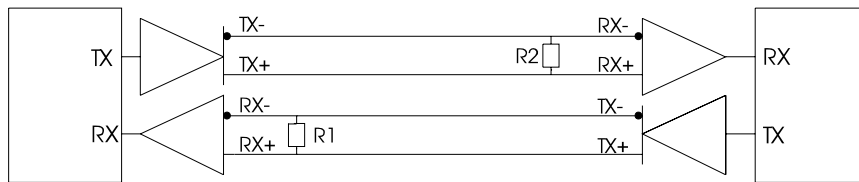

R1 & R2 -- Line Termination (100 Ohms)

Typical RS-485

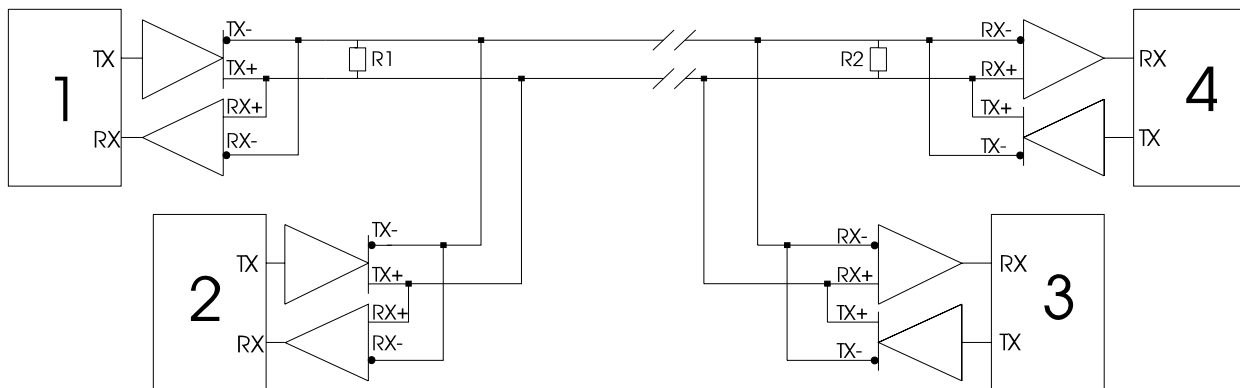

TECHNICAL SUPPORT

Commtech provides extensive technical support and application suggestions. Most of the problems that occur with the *SuperFASTCOM-cPCI* can be corrected by double-checking the switch positions, your cables and your program. We recommend that you build the loop back plug that is described in the Programming section of this manual. With that plug, you can quickly isolate the problem to the board, cables, or software.

If you still have unresolved questions, use the following procedure to get technical support:

1. Call our Technical Support Staff at (316) 636-1131. They are on duty from 9:00 AM to 5:00 PM Central Time.
2. Ask for technical support for the *SuperFASTCOM-cPCI*. Be ready to describe the problem, your computer system, your application, and your software.
3. If necessary, our staff will give you an RMA number (Return Material Authorization). Use this number on the mailing label and in all references to your board. Put the board back in its static bag and in its box. Ship the board back to us as directed.
4. If you prefer, you may FAX a description of the problem to us at (316) 636-1163, or we can be reached on the Internet at "<http://www.commtech-fastcom.com/TechSupport.html>" or by email at "techsupport@commtech-fastcom.com".

FASTCOM LIMITED LIFETIME WARRANTY

Commtech's entire FASTCOM product line is covered by a limited lifetime warranty against defects in workmanship. This warranty is available only to the original purchaser and only covers defects in our workmanship. Any FASTCOM board that is returned to Commtech will, at the option of Commtech, be repaired or replaced at no charge -- except for circumstances excluded by this warranty.

A Return Materials Authorization (RMA) number must be obtained from Commtech before a return will be accepted. Please contact us via telephone or email to obtain an RMA number.

You are responsible for shipping charges when you return a FASTCOM board to Commtech. We will pay the shipping charges to send the board back to you if a defect in workmanship is found. However, if no defect in workmanship is found, or the board is not found to be defective, or the any of the following warranty exclusions occur, you will be responsible for shipping charges both ways.

Warranty Exclusions

This warranty does not cover problems or damage resulting from, but not limited to, the following:

1. Any modification, misuse, abuse, disassembly, misapplication, or unauthorized repair by anyone other than Commtech.
2. Any improper operation, including any use not in accordance with any verbal product instructions or documentation.
3. Connection to an improper voltage supply or ESD damage.
4. Any other cause not related to workmanship.

Non-Warranty Repairs

We can provide a quote for non-warranty repairs upon request.

If any Commtech product is damaged such that it cannot be repaired, you can return it to Commtech for replacement under our *Non-Repairable Replacement* policy, regardless of the cause of damage. Commtech will replace the unit at 60% of the then-current list price.

Limitation of Liability

Commtech shall not be liable for any special, incidental, indirect, or consequential damages whatsoever, including but not limited to loss of profits, revenue, or data (whether direct or indirect), or commercial loss for breach of any express or implied warranty on your product even if Commtech has been advised previously of the possibility of such damages. Commtech's liability, in any case, shall not exceed the original product purchase price.



APPENDIX A

INFINEON 20534

TECHNICAL DATA

