

# **FASTCOM<sup>®</sup> ADAPTERS**

## ***SUPERFASTCOM***

**Four Channel High Speed Synchronous Serial Interface  
for PCI Bus**

**Hardware Reference Manual**

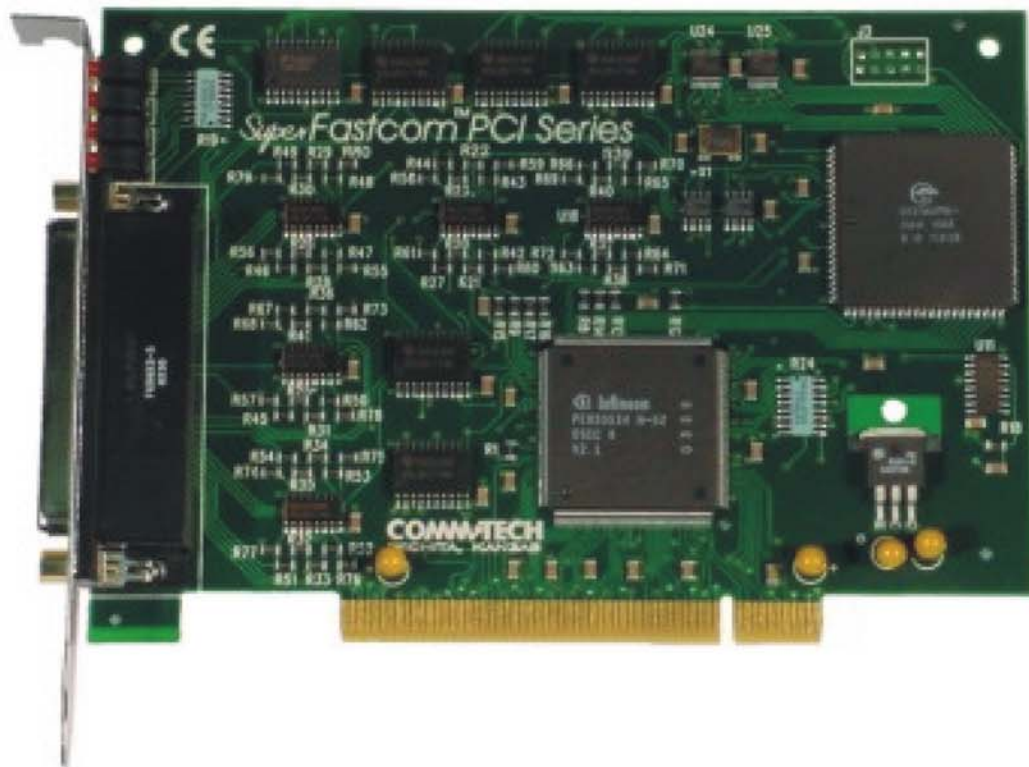

**COMMTECH, INC.**  
9011 E 37th St N  
Wichita KS USA  
67226-2006





# COMMTECH

9011 E. 37TH STREET N.  
WICHITA, KANSAS 67226-2006  
(316) 636-1131  
FAX (316) 636-1163

<http://www.commtech-fastcom.com/>

COPYRIGHT (C) 2001, 2002, 2003, 2004, 2005, 2010  
All rights reserved, including those to reproduce this document or parts thereof in  
any form without permission in writing from Commtech, Inc.

FASTCOM and the "Alpha Lemur" are registered trademarks of Commtech, Inc.

Microsoft is a registered trademark of Microsoft Corporation.  
WINDOWS is a trademark of Microsoft Corporation.



## REVISION NOTES

<u>REVISION</u>	<u>PAGE NUMBER</u>	<u>CHANGES MADE</u>
2.1	12	Revised Windows 2000 test procedure
2.2	20	Changed warranty to 2 years
2.3	5	Added SuperFASTCOM Cable to packing list
2.4	11	Added link to installation manual
2.5	19	Updated contact information
2.6	10	Removed RS-530 references
2.7	1	Changed board revision level on CE certificate
	13	Removed unnecessary register setup information and repaginated
2.8	1	Added SuperFastcom family information
2.9	18	Changed warranty period to lifetime
2.10	12-13	Added more programs to list
2.11	19-21	Added "Errata" section Modified features to agree with errata
2.12	21	Appended to "Errata" section
2.13	11	Add hardware installation notes 2a & 2b
2.14	14	Added register offset descriptions
2.15	23	Changed warranty to limited lifetime



# CONTENTS

<a href="#">“CE” CERTIFICATE</a> .....	1
INTRODUCTION	
<a href="#">Description / Block Diagram</a> .....	3
<a href="#">Specifications / Features</a> .....	4
<a href="#">Board Layout</a> .....	5
<a href="#">Communications Overview</a> .....	6
<a href="#">Comparison to ESCC Family</a> .....	8
CABLE	
<a href="#">Cable Configuration</a> .....	9
<a href="#">DB25 Connector Description</a> .....	10
INSTALLATION	
<a href="#">Hardware Installation</a> .....	11
<a href="#">Software Installation</a> .....	11
TESTING THE INSTALLATION	
<a href="#">Windows 2000 Test Procedure</a> .....	11
<a href="#">SOFTWARE UTILITIES</a> .....	12
<a href="#">PROGRAMMING</a> .....	14
<a href="#">MEMORY MANAGEMENT</a> .....	16
<a href="#">RS-422/485</a> .....	17
<a href="#">Termination Resistance</a> .....	18
<a href="#">PROGRAMMABLE CLOCK GENERATORS</a> .....	19
<a href="#">ERRATA</a> .....	20
<a href="#">TECHNICAL SUPPORT</a> .....	23
APPENDIX A	
<a href="#">Infineon 20534 Technical Data Sheet</a> .....	24





## **EUROPEAN UNION DECLARATION OF CONFORMITY**

### **Information Technology Equipment**

The Company COMMTECH, INC. declares under its own and full responsibility that the product

**" SuperFastcom - Revision 2.0 "**

on which is attached this Certificate is compliant to the "89/336/EEC" Directive, amended by 92/31/EEC and 93/88/EEC.

[ ] The product identified above complies with the requirements of the above EU Directive by meeting the following standards:

- EN 50081-1 (1992) EMC Generic Emission Standard - Part 1, Residential, Commercial and Light Industry
  - EN 55022 (1995), CISPR 22 (1993) Limits and Methods of Measurement of Radio Disturbance Characteristics of Information Technology Equipment, 30 MHz - 1 GHz, Class B Limits
- EN 50082-1 (1992) EMC Generic Immunity Standard - Part 1, Residential, Commercial and Light Industry
  - IEC 801-2 (1984), Method of Evaluating Susceptibility to Electrostatic Discharge, Level 4
  - IEC 801-3 (1984), Radiated Electromagnetic field Requirements, Level 3
  - IEC 801-4 (1988), Electrical Fast Transient/Burst Requirements, Level 2

Products listed on this declaration are exempt from the requirements of the 73/23/EEC directive due to the input voltage specification as stated in Article 1 of the directive.

The technical documentation required to demonstrate that this product meets the requirements of the EMC Directive has been compiled by the signatory below and is available for inspection by the relevant enforcement authorities.

In WICHITA, KS on December 31st of 1995

**COMMTECH**<sup>TM</sup>  
COMMUNICATION • TECHNOLOGIES

9011 E. 37th Street North

Wichita, KS 67226-2006

(316) 636-1131

Fax (316) 636-1163



Mr. Glen R. Alvis

Chief Engineer





## INTRODUCTION

The new *SuperFASTCOM* PCI adapter is a very high-speed, four channel, synchronous serial communications adapter designed for Windows- and LINUX-based industrial/commercial systems. Its outstanding features include data rates up to 40 Mbits/s and the ability to buffer up to 4 Gigabytes of data (Windows 2000) in system memory.

The *SuperFASTCOM* supports standard synchronous protocols (HDLC, SDLC) and their variations, as well as standard asynchronous data formats at data rates up to 40 Mbits/s. The **on-board clock generator** provides a high-speed clock source for your system and eliminating the need for an external clock. The board also features high-speed RS-422/RS-485 drivers/receivers with on-board line termination.

Programming is simplified with the inclusion of drivers, example programs and comprehensive documentation supplied on the Fastcom CD. The *SuperFASTCOM* provides high speed and high reliability while greatly reducing development time and system complexity.

The *SuperFASTCOM* family includes:

Form Factor	Line Type	Ports
PCI	RS422/485 OR RS232	4
PC/104+	RS422/485	1 or 2
CompactPCI	RS422/485	4
CompactPCI Rear IO	RS422/485	4

The following diagram illustrates the basic structure of the *SuperFASTCOM*:

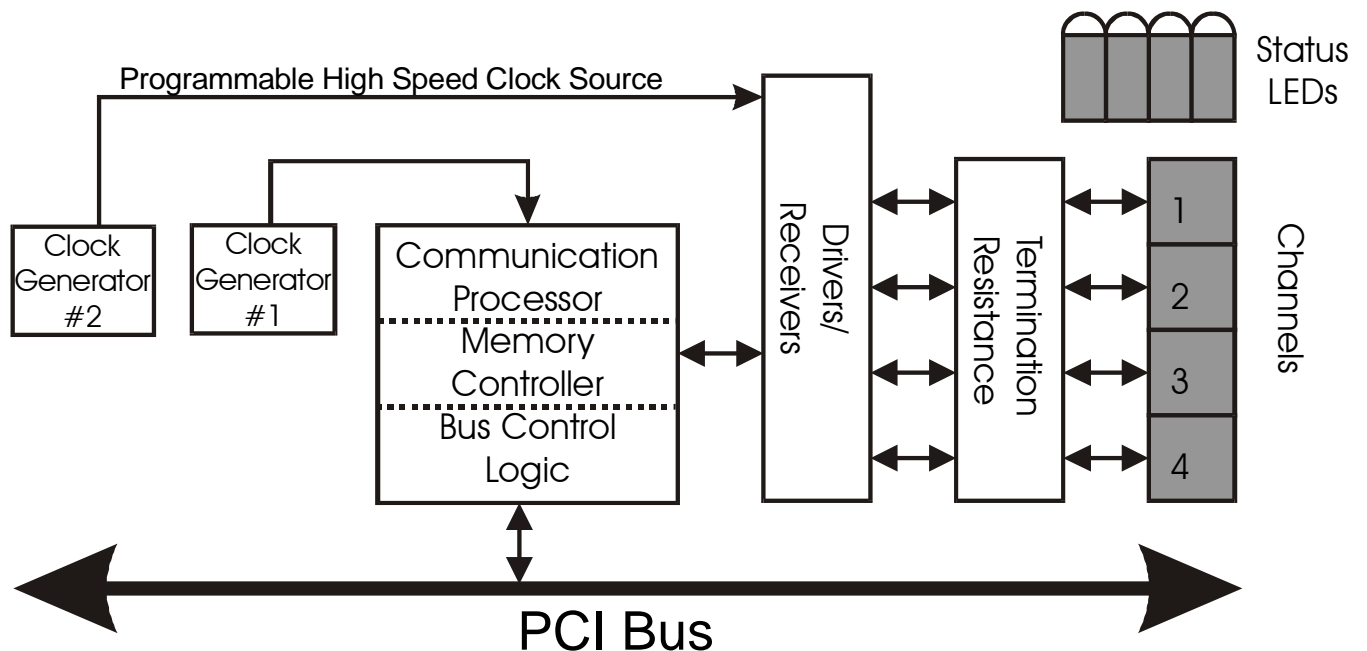

## SPECIFICATIONS:

COMMUNICATION CONTROLLER:	INFINEON 20534
OS SUPPORT:	Windows XP, 2000, NT4; Linux
DATA RATE:	All baud rates up to 40 Mbps
DATA BUFFERING:	Up to 4 Gbytes (Windows) Up to 52 Mbytes per channel (LINUX)
DRIVERS/RECEIVERS:	High Speed RS-422/RS-485
SIGNALS:	TxD, RxD, RTS, CTS, DCD, TT, RT, ST
CONNECTOR CONFIGURATION:	DB-78 to four DB-25 connectors
BUS INTERFACE:	32-bit PCI Ver. 2.1
POWER REQUIREMENTS:	450mA @ +5 (typical)
ENVIRONMENT:	
Operating Temperature Range:	0 to 70 C
Humidity:	0 to 90% (non-condensing)
MEAN TIME BETWEEN FAILURES:	24.61 Yrs
CERTIFICATION:	FCC compliant, CE marked

## FEATURES:

Four independent channels

Status LEDs for system development/debugging

Two programmable on-board clock generators

“Switchless” design for durability and reliability

Hardware documentation and software included on CD

Made in Wichita, KS U.S.A.

# SuperFASTCOM

## BOARD LAYOUT

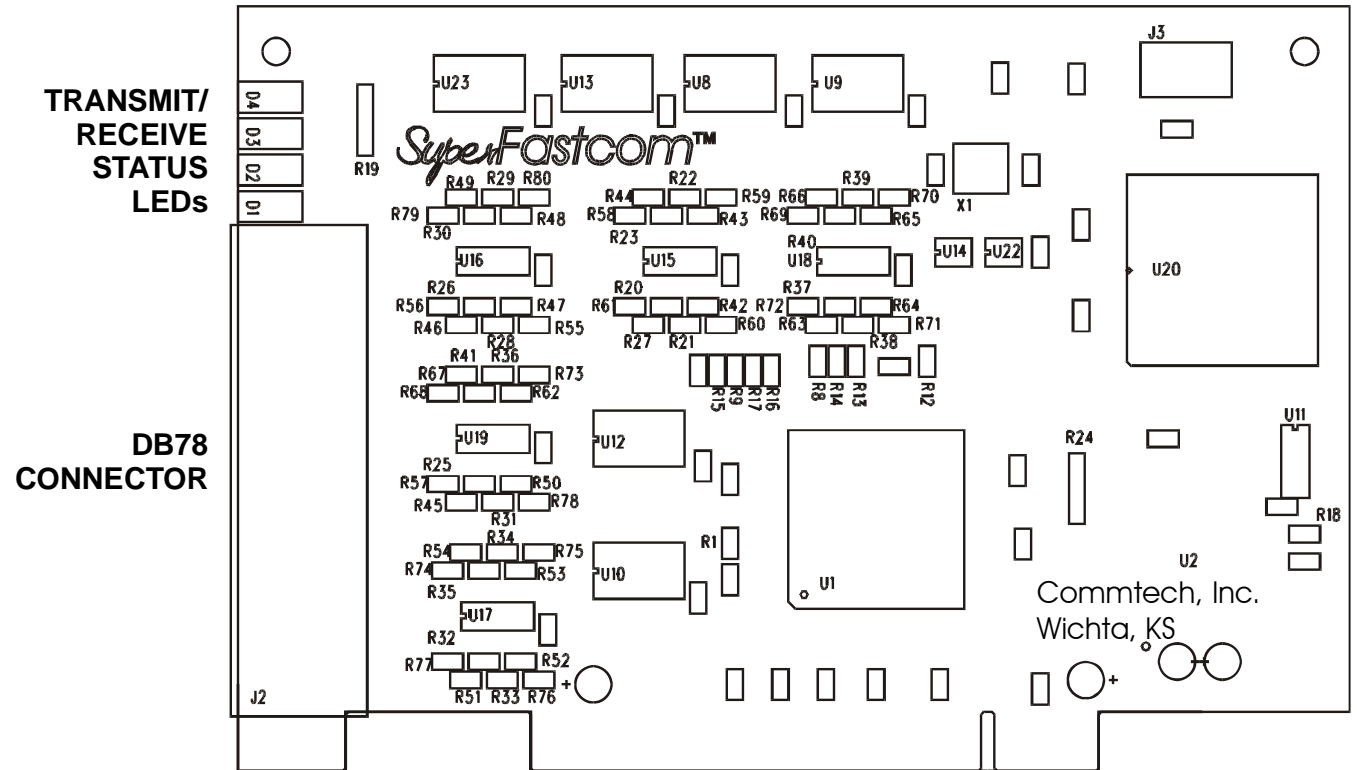

### PACKING LIST:

SuperFASTCOM Card  
 SuperFASTCOM Cable  
 FASTCOM CD

If an omission has been made, please call technical support for a replacement.

## COMMUNICATIONS OVERVIEW

- HDLC/SDLC Protocol Modes
  - Automatic flag detection and transmission
  - Shared opening and closing flag
  - Generation of interframe-time fill '1's or flags
  - Detection of receive line status
  - Zero bit insertion and deletion
  - CRC generation and checking (CRC-CCITT or CRC-32)
  - Transparent CRC option per channel and/or per frame
  - Programmable Preamble (8 bit) with selectable repetition rate
  - Error detection (abort, long frame, CRC error, short frames)
- Bit Synchronous PPP Mode
  - Bit-oriented transmission of HDLC frame (flag, data, CRC, flag)
  - Zero bit insertion/deletion
  - 15 consecutive '1' bits aborts sequence
- Octet Synchronous PPP Mode
  - Octet-oriented transmission of HDLC frame (flag, data, CRC, flag)
  - Programmable character map of 32 hard-wired characters (00 H -1F H)
  - Four programmable characters for additional mapping
  - Insertion/deletion of control-escape character (7D H) for mapped characters
- Asynchronous (ASYNC) Protocol Mode
  - Selectable character length (5 to 8 bits)
  - Even, odd, forced or no parity generation/checking
  - 1 or 2 stop bits
  - Break detection/generation
  - In-band flow control by XON/XOFF
  - Immediate character insertion
  - Termination character detection for end of block identification
  - Time out detection
  - Error detection (parity error, framing error)
- BISYNC Protocol Mode
  - Programmable 6/8-bit SYN pattern (MONOSYNC)
  - Programmable 12/16-bit SYN pattern (BISYNC)
  - Selectable character length (5 to 8 bits)
  - Even, odd, forced or no parity generation/checking
  - Generation of interframe-time fill '1's or SYN characters
  - CRC generation (CRC-16 or CRC-CCITT)
  - Transparent CRC option per channel and/or per frame
  - Programmable Preamble (8 bit) with selectable repetition rate
  - Termination character detection for end of block identification
  - Error detection (parity error, framing error)
- Extended Transparent Mode
  - Fully bit transparent (no framing, no bit manipulation)
  - Octet-aligned transmission and reception
- Protocol and Mode Independent
  - Data bit inversion

- Data overflow and under run detection
- Timer

## **Protocol Support**

- Address Recognition Modes
  - Mode 0 - No address recognition
  - Mode 1 - 8-bit (high byte) address recognition
  - Non-Auto Mode - 8-bit (low byte) or 16-bit (high and low byte) address recognition

## **General**

- On-chip Rx and Tx data buffer (the buffer size is 128 32-bit words each)
- Programmable buffer size in transmit direction per channel; buffer allocation in receive direction on request.
- Programmable watermark for receive channels to control transfer of receive data to host memory.
- Two programmable watermarks for each transmit channel, i.e. one controlling data loading from host memory and one controlling transfer of transmit data to the corresponding Serial Communication Controller (SCC).
- Internal test loop capability.

## SuperFASTCOM / ESCC FAMILY COMPARISON

### Enhancements to the ESCC Serial Core

The SuperFASTCOM adapter contains the core logic of the ESCC2 V3.2A as the heart of the device. Some enhancements are incorporated in the SuperFASTCOM. These are:

- 16-Kbyte packet length byte counter
- Enhanced address filtering (16-bit maskable)
- Enhanced time slot assigner
- Support of high data rates (45 Mbit/s for DS3 or 52 Mbit/s for OC1). Protocol support is limited to HDLC Sub-modes without address recognition.

### Simplifications of the ESCC Serial Core

The following features of the ESCC core have been removed:

- SDLC Loop mode
- Extended transparent mode 0 (this mode provided octet buffered data reception without usage of FIFOs; the SuperFASTCOM supports octet buffered reception via appropriate threshold configurations for the SCC receive FIFOs)

## CONFIGURATION FOR SuperFASTCOM CABLE ASSEMBLY

The cable provided with your SuperFastcom adapter splits each channel from the DB78 to into four DB 25 male connectors.

<u>SIGNAL</u>	<u>DB25 #</u>	<u>DB78 PIN NUMBER</u>			
		<u>CHANNEL 1</u>	<u>CHANNEL 2</u>	<u>CHANNEL 3</u>	<u>CHANNEL 4</u>
GND	1	58	38	9	48
GND	7	68	29	10	49
SD-	2	70	13	22	62
SD+	14	50	32	2	46
RD-	3	73	36	6	65
RD+	16	53	17	26	42
RTS-	4	71	33	3	63
RTS+	19	51	14	23	45
CTS-	5	74	18	27	66
CTS+	13	54	37	7	41
DCD-	10	76	31	8	40
DCD+	8	57	12	28	60
TT-	11	69	30	1	61
TT+	24	52	11	21	47
RT-	9	72	16	25	64
RT+	17	56	35	5	43
ST-	12	75	34	4	67
ST+	15	55	15	24	44
PRGCLK-	23	77	N/A	N/A	N/A
PRGCLK+	20	78	N/A	N/A	N/A

## SuperFASTCOM DB25 CABLE CONNECTOR DESCRIPTION

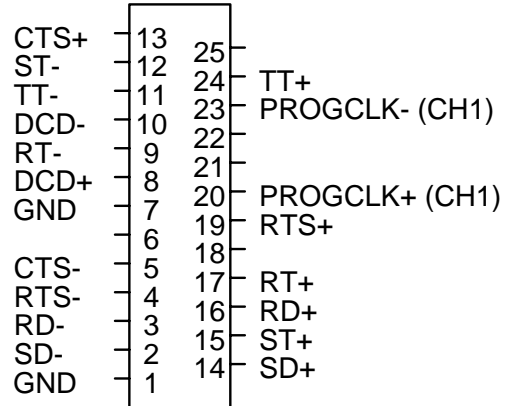

### PIN DESCRIPTIONS

<u>PIN#</u>	<u>DESCRIPTION</u>	<u>422 TYPE</u>	<u>CONNECTED TO</u>
1	SHIELD/GROUND		GND
7	SIGNAL/GROUND		GND
2	TRANSMIT DATA	A	SD-
14	TRANSMIT DATA	B	SD+
3	RECEIVE DATA	A	RD-
16	RECEIVE DATA	B	RD+
4	REQUEST TO SEND	A	RTS-
19	REQUEST TO SEND	B	RTS+
5	CLEAR TO SEND	A	CTS-
13	CLEAR TO SEND	B	CTS+

### CLOCK SIGNALS

<u>PIN#</u>	<u>DESCRIPTION</u>	<u>422 TYPE</u>	<u>CONNECTED TO</u>
8	DATA CARRIER DETECT	A	DCD+
10	DATA CARRIER DETECT	B	DCD-
24	TRANSMIT CLOCK OUT	A	TT+
11	TRANSMIT CLOCK OUT	B	TT-
17	RECEIVE CLOCK IN	A	RT+
9	RECEIVE CLOCK IN	B	RT-
15	TRANSMIT CLOCK IN	A	ST+
12	TRANSMIT CLOCK IN	B	ST-

### Special Signals On Cable 1 Only

Pin 20	PROGCLK +	Programmable clock output
Pin 23	PROGCLK-	

## INSTALLATION

Important: Observe Electrostatic Discharge (ESD) precautions when handling the SuperFASTCOM board.

1. Unpack the *SuperFASTCOM* adapter. Keep the box and static bag for warranty repair returns.
2. Select an open PCI slot in your PC.
  - a. *The SuperFastcom requires that the selected PCI slot be capable of bus mastering. The card will not function correctly if installed into a non-bus mastering slot.*
  - b. *If possible, install the SuperFastcom into one of the Primary PCI slots. If you are installing into a Secondary PCI slot (i.e., on the other side of a PCI bridge), make sure that your motherboard's PCI bridge is properly installed in your operating system before proceeding with the installation. If you do not have more than three PCI slots, then none of the slots are secondary.*
3. After removing the blank bracket from your PC, install the *SuperFASTCOM* in the PC by pressing it firmly into the slot. Install the bracket screw to hold it firmly in place.
4. Re-install the cover on your PC.
5. Install the *SuperFASTCOM* cable.

## Software Installation

Select the link above to open the Installation Manual. Under *SuperFastcom*, select your operating system and follow the instructions. When you are finished, select *SuperFastcom* from the list at the end of the *SuperFastcom* section to return to this manual.

## TESTING THE INSTALLATION

To fully test the installation of your SuperFastcom, you will need to build a "loop back plug". Materials needed are a DB25 female receptacle (solder cup style) and a few short pieces of 20 or 24 AWG stranded wire. Jumper the pins together on the DB25 as illustrated:

### WINDOWS 2000 TEST PROCEDURE

1. Place the loop back plug onto the Port 1 connector.

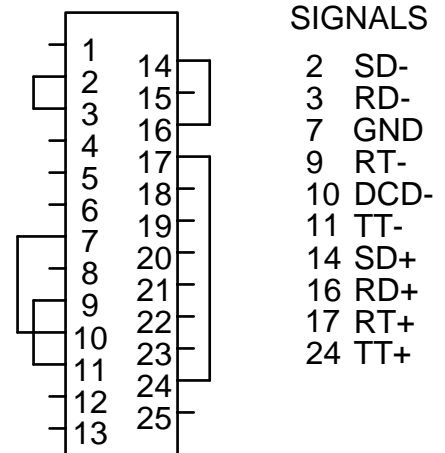

2. Open a console/DOS window.
3. Change directories to where you installed/copied the software.
4. Execute: setclock 0 4000000
5. Execute: sfcset 0 hdlcset
6. Execute: loopback 0 h

The green and red LEDs for port 1 should be blinking/on. Wait a few moments, press a key, and the errors/number of bytes sent through the loop will be displayed. The numbers will vary depending on how long you allow the test to run

The rest of the ports can be checked by executing:

```
sfcset 1 hdlcset
loopback 1 h
```

```
sfcset 2 hdlcset
loopback 2 h
```

```
sfcset 3 hdlcset
loopback 3 h
```

## SOFTWARE UTILITIES

These programs and their source can be found on the Fastcom CD or downloaded from our website at <http://www.commtech-fastcom.com/>. They are meant to be used as educational tools and programming references when designing your own software.

- sfcset.exe            Use to change register settings in conjunction with the hdlcset file
- hdlcset, asyncset, bisyncset  
Generic settings files to be used with sfcset.exe
- getclock.exe        returns programmable clock #1 rate (osc)
- getclock2.exe      returns programmable clock #2 rate (progclk +/-)
- setclock.exe        sets the programmable clock #1 (osc)
- setclock2.exe      sets the programmable clock #2 (prograclk +/-)
- loopback.exe        user program to effect a loopback on a SuperFastcom channel
- sfcmf.exe
  - Install your loopback plug onto the SuperFastcom.
  - Run "sfcmf.exe".
  - Select "connect" from the menu.
  - A dialog will open. Select the port to use (0,1,2,3).
  - Click on "OK".
  - An info box will open; click "OK".

- Type a message: "Hello, world".
  - What you type should show up under "Transmit" in the window.
  - Select "Send" from the menu.
  - The message will appear in red under "Received".
  - To open a different port, either select "File->New" or "Disconnect" from the menu.
- 
- readlb.exe            user program to read a SuperFastcom special register
  - writelb.exe        user program to read a SuperFastcom special register
  - readreg.exe        user program to read a 20534 register
  - writereg.exe      user program to write to a 20534 register
  - send.exe            user program that opens a file and sends it through port 0
  - flushrx.exe        user program to flush the SuperFASTCOM receiver/buffers
  - flushtx.exe        user program to flush the SuperFASTCOM transmitter/buffers
  - getbufs.exe        user program to get buffering/descriptor parameters for a port
  - setbufs.exe        user program to set buffering/descriptor parameters for a port
  - getclock.exe      user program to get the current clock generator settings
  - getclock2.exe     user program to get the current program clock generator settings
  - read\_file\_hdlc.exe user program to read hdlc frames from a port and stuff them to a file
  - sendfile.exe        user program to send a file out a SuperFastcom port
  - setchecktimeout.exe user mode function to set the timeout timer in the driver that checks for frames to be returned or sent
  - setfs6131clock.exe user program that sets the fs6131 clock generator which is only valid if you have an extended temperature card with fs6131's on it
  - setrfi.exe         user program to mask/unmask the frame end interrupt indication for receive descriptors
  - setrirq.exe        user program to set the interrupt rate for receive descriptors
  - settirq.exe        user program to set the interrupt rate for transmit descriptors
  - settfi.exe         user program to mask/unmask the frame end interrupt indication for transmit descriptors
  - simuln200.exe     user program to generate 26 byte hdlc frames simulating an LN200
  - st\_tt.exe            user program to switch the onboard txclk multiplexer between the TT output and the ST input
  - status.exe         user program to read status from a SuperFastcom port

## PROGRAMMING

Refer to the enclosed FASTCOM CD for example programs, product updates, and software for testing your installation. Refer to the Infineon PEB 20534 User's Manual for register information.

Local Bus Interface for PEB 20534 - Byte accesses

### Register at offset 0

#### Channel 1

Bit 0 1 = receive constantly enabled  
0 = receive enabled only when RTS is off  
Bit 1 1 = transmit constantly enabled  
0 = transmit enabled only when RTS is on  
Bit 2 1 = TT constantly enabled  
0 = TT enabled only when RTS is on  
Bit 3 No function

#### Channel 2

Bit 4 1 = receive constantly enabled  
0 = receive enabled only when RTS is off  
Bit 5 1 = transmit constantly enabled  
0 = transmit enabled only when RTS is on  
Bit 6 1 = TT constantly enabled  
0 = TT enabled only when RTS is on  
Bit 7 No function

### Register at offset 1

#### Channel 3

Bit 0 1 = receive constantly enabled  
0 = receive enabled only when RTS is off  
Bit 1 1 = transmit constantly enabled  
0 = transmit enabled only when RTS is on  
Bit 2 1 = TT constantly enabled  
0 = TT enabled only when RTS is on  
Bit 3 No function

#### Channel 4

Bit 4 1 = receive constantly enabled  
0 = receive enabled only when RTS is off  
Bit 5 1 = transmit constantly enabled  
0 = transmit enabled only when RTS is on  
Bit 6 1 = TT constantly enabled  
0 = TT enabled only when RTS is on  
Bit 7 No function

### Register at offset 2

#### Channel 1

Bit 0 0 = ST connected to TXCLK  
1 = ST not connected  
Bit 1 0 = TT connected to TXCLK  
1 = TT not connected

#### Channel 2

Bit 2 0 = ST connected to TXCLK  
1 = ST not connected  
Bit 3 0 = TT connected to TXCLK  
1 = TT not connected

#### Channel 3

Bit 4 0 = ST connected to TXCLK  
1 = ST not connected  
Bit 5 0 = TT connected to TXCLK  
1 = TT not connected

#### Channel 4

Bit 6 0 = ST connected to TXCLK  
1 = ST not connected  
Bit 7 0 = TT connected to TXCLK  
1 = TT not connected

**Offset 0 & 1** – These bits are generally for choosing between 422 and 485 communications.

- Receive constantly enabled – (default) for RS-422 communication
- Receive enabled only when RTS is off – also Rx Echo Cancel; disables the receiver when transmitting so that you do not receive everything that you transmit when using 2-wire RS-485.
- Transmit constantly enabled – (default) for RS-422 communication
- Transmit enabled only when RTS is on – turns off the transmitter when it is not actively sending data so that it does not contend with another transmitter on the data bus

- TT constantly enabled – (default) for RS-422 communications
- TT enabled only when RTS is on – turns off the transmit clock when it is not actively sending data so that it does not contend with another transmitter on the clock bus

**Offset 2** – These bits are for setting the transmit clock direction. The PEB20534 has only one transmit clock pin that can be an input or an output using CCR0:TOE. If that pin is configured to be an output, then it must be connected to a line driver. If that pin is configured to be an input, then it must be connected to a line receiver. The ST pin is TxClk as an input and the TT pin is TxClk as an output.

- ST connected to TxClk – TxClk connected to the ST input pin. **Never set CCR0:TOE=1 when setting this bit!**
- ST not connected to TxClk – (default) TxClk not connected to the ST input pin
- TT connected to TxClk – (default) TxClk connected to the TT output pin
- TT not connected to TxClk – TxClk not connected to the TT output pin.

Note: It is possible to configure the TxClk pin as an input TOE=0, and connect it to both the TT and ST pins. This will allow the external clock from the ST pins to be outputted on the TT pins.

## MEMORY MANAGEMENT

High-speed communications requires that large amounts of transmitted/received data be buffered so as to prevent data loss and maintain data throughput. The SuperFASTCOM is designed to utilize system memory directly, bypassing the system processor. The SuperFASTCOM accesses system memory through high-speed PCI Bus Mastering, using its on-board bus master controller and supplied software. This procedure for direct memory access (DMA) is by far the fastest, most efficient method of handling the large amounts of data that high-speed communications generates. Data is transferred to and from the SuperFASTCOM adapter at data bus speed. Buffering a high-speed data stream is critical in order to maintain data integrity and reliability, to avoid data loss, and to prevent data overrun. The SuperFASTCOM does all this with minimal system processor involvement, therefore there is no reduction in processor performance due to data communication overhead.

*How it works* - The user designates in his program how much system memory will be allocated to communications: the more memory in your system, the more you can allocate to the communication process. As data is received, the on-board communication processor fills a small local buffer. When this is full, the bus master controller on the SuperFASTCOM transfers this data directly to system memory. The local buffer is reset and the process begins again. Transmitting data works in reverse; data from system memory is directly transferred to the local buffer on the SuperFASTCOM. When the local buffer is empty, new data from memory is directly transferred in. All of this occurs without slowing or interfering with the system processor.

The high speed PCI Bus Mastering procedure for direct memory access provides the fastest, most efficient method of data transfer. It also improves efficiency and reduces the cost of the SuperFASTCOM board by eliminating the need for on-board memory or a processor.

## RS-422 / RS-485

Most engineers have worked with RS-232 devices at least once in their career. If you have never worked with RS-422 or RS-485 devices, you will be pleased to know that working with the SuperFASTCOM is not much different from working with an RS-232 device.

The RS-422 standard was developed to correct some of the deficiencies of RS-232. In commercial and industrial applications, RS-232 has some significant problems. First, the cable length between RS-232 devices must be short (usually less than 50 feet at 9600 Baud). Second, many RS-232 errors are the result of cables picking up normal industrial electrical noises such as fluorescent lights, motors, transformers, and other EMF sources. Third, RS-232 data rates are functionally limited to 19.2K Baud. On the other hand, the newer RS-422 standard makes cable lengths up to 5000 feet possible and is highly immune to most industrial noises. Data rates are also improved -- the SuperFASTCOM features data rates up to 40 Mega Baud. These improvements were made possible by differentially driving and receiving the data as opposed to the single ended method employed by the RS-232 standard. With the RS-422 standard, the transmit signal (TX in RS-232) is a differential signal consisting of SD+ and SD-; the receive signal (RX in RS-232) consists of RD+ and RD-.

Another draw back of RS-232 is that more than two devices cannot share a single cable. This is also true of RS-422, and that's why the RS-485 standard was developed. RS-485 offers all of the benefits of RS-422 and also allows multiple units (up to 32) to share the same twisted pair. RS-485 is often referred to as a "multi-drop" or "two-wire, half duplex" network because the drivers (transmitters) and receivers share the same two lines. In fact, up to 32 stations can share the same "twisted pair". In order for an RS-485 system to work, only one driver (transmitter) can occupy the network at a time. This means that each station on the network must control the enabling/disabling of their drivers in order to avoid network conflicts. If two drivers engage the network at the same time, data from both will be corrupted. In RS-485 mode, the receivers are always enabled.

For a more detailed description of RS-422 and RS-485, we recommend the following references:

LINEAR AND INTERFACE CIRCUITS APPLICATIONS, Volume 2: Line Circuits, Display Drivers. By D.E. Pippenger and E. J. Tobaben. Published 1985 by Texas Instruments. ISBN-0-89512-185-9

Note: This book may be difficult to find in a bookstore. The best place to get it is directly from Texas Instruments or from one their component dealers. Publication # SLYA002.

"Driver/Receiver Family Extends Data-Link Performance", ELECTRONIC PRODUCTS, January 15, 1985. By Dale Pippenger and Joe Miller

## TERMINATION RESISTANCE

In both the RS-422 and the RS-485 mode, the receiver end of the cable between two stations must be terminated with a resistor equal to the characteristic impedance of the wire. This is to prevent signal reflections in the wire and to improve noise rejection. However, **you do not need to add a terminator resistor to your cables when you use the SuperFastcom. The termination resistance is built in.** We have installed a terminator resistor for each receiver: between each RD+ and RD- and between CTS+ and CTS- for each channel.

If you are using the SuperFastcom in a multi-drop network, the termination resistor should be removed from all units except the first and last (see the RS-485 illustration below). Call for technical support if you need to modify the resistor. You may also order the SuperFastcom without the termination resistor installed (it is easier to add the resistor than to remove it). Observe the resistors in the following drawings and remember that they are built into the SuperFastcom:

### Typical RS-422

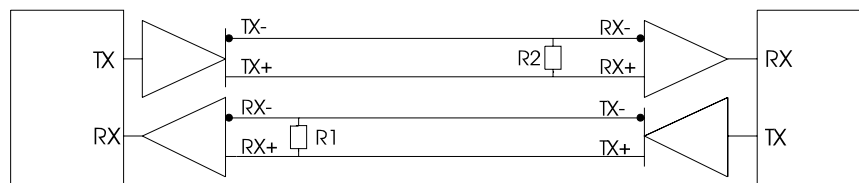

R1 & R2 -- Line Termination (100 Ohms)

### Typical RS-485

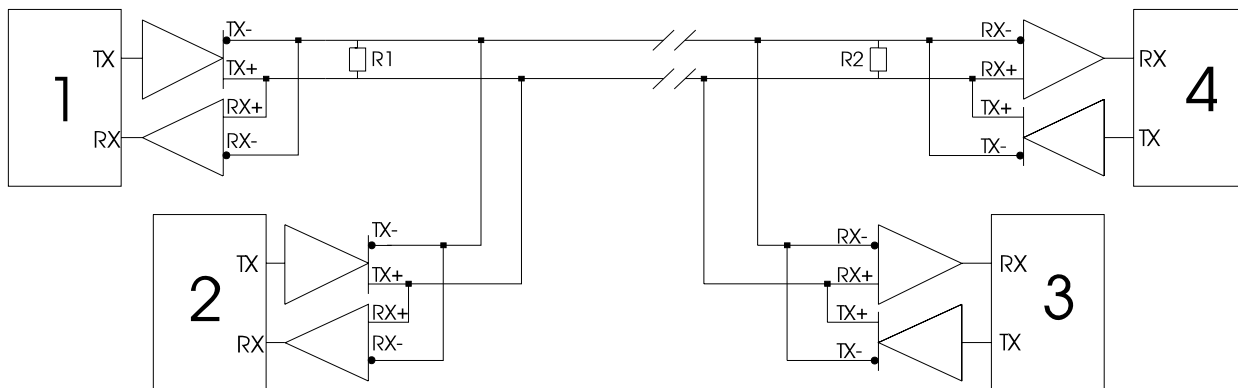

## PROGRAMMABLE CLOCK GENERATORS

The SuperFastcom features two Programmable Clock Generators. Each is a Cypress ICD2053B chip, which offers a fully user-programmable phase-locked loop clock pulse generator in a single 8-pin package. The output of the generator may be changed "on the fly" to any desired frequency value. The ability to dynamically change the output frequency adds a whole new degree of freedom for the designer.

### Why have two clock generators?

The first clock generator (the **OSC** clock generator) provides the clock pulse to the PEB20534 communications processor chip. Its maximum frequency is 33MHz and is programmable via the GPP register (bits 8 and 9). The second clock generator (the **PROGCLK** clock generator) directly drives the PROGCLK+ and PROGCLK- output signals (PIN 20 and 23 on Cable #1). The PROGCLK has a maximum frequency of 40MHz and is programmable via the GPP register (bits 10 and 11). The PROGCLK is designed to provide a system wide high-speed clock pulse.

For additional information on the Cypress ICD2053B, please review the [data sheet](#).

### An important fact about the clock generator

There is only one clock input line on the PEB 20534 communications chip and it is connected to the **OSC** clock generator on the SuperFastcom board. The **OSC** clock generator can be programmed from any channel (SFC, SFC1, SFC2, SFC3) but you are programming the same clock generator (the OSC clock generator) in each case. Just keep in mind that the baud rate generators are independent for each channel, but all four baud rate generators are fed from one clock source (the OSC clock generator). If you change the OSC clock generator rate you will change the input to the baud rate generators for all channels.

If you have multiple baud rates that must be generated on multiple channels, you should select an OSC clock rate from which all of the required baud rates can be derived. *Changing the OSC clock generator output will affect the baud rates of all channels!!!!*

## ERRATA

The errata listed below are known issues with the either Superfastcom board or the PEB20534 controller itself. For more information regarding any of these issues, please contact Commtech [technical support](#).

- **Serial Bus Configuration Timing Modes**

The SuperFastcom was not designed to make use of Serial Bus Configuration timing modes 1 and 2. Do not attempt to configure CCR0:SC(2..0) to use these modes as they will not work correctly.

- **Maximum Value of Baudrate Generator**

The maximum value 'BRM' in register BRR must not exceed  $M = 14$  (the specified maximum value is  $M = 15$ ). This limits the baud rate generator unit to frequency division factors in the range  $k = 1 \dots 1,048,576$ , instead of  $k = 1 \dots 2,097,152$ .

- **DPLL Algorithm for FM0, FM1 and Manchester Encoding**

Recovering the clock from an FM0-, FM1- or Manchester-encoded receive data stream using the DPLL circuitry is not working. The DPLL-asynchronous interrupt (PLLA) occurs continuously.

- **HDLC Mode: False Receive Status Byte**

The receive status byte RSTA belonging to an already received frame is overwritten by 0x00 if the following two conditions are met:

1. The interframe timefill number of '1' bits between the closing flag and the opening flag of the next frame is in the range of [1 - 5].
2. The receive CRC checking mode is selected to transfer the receive CRC into the receive FIFO (CCR2:RCRC = '1').

In all cases meeting the first condition, the number of '1' bits is treated as an invalid HDLC frame. This frame is prevented from being reported or forwarded to the receive FIFO because of its invalid length. However the serial receive logic calculates a receive status byte RSTA = 0x00 (invalid frame).

If the receive CRC is selected to be transferred to the receive FIFO (second condition), the receive status value of the previous valid frame is not yet transferred when calculating the invalid receive status byte. Thus the original receive status value is overwritten by 0x00 marking the previous frame as 'invalid'.

**Workaround:** The error cannot occur if bit CCR2:RCRC is set to '0', i.e. receive CRC is not transferred to the receive FIFO. Otherwise (if CCR2:RCRC = '1') reception of less than 6 consecutive '1' bits as interframe timefill must be avoided. This can be achieved by the transmitter either selecting interframe timefill flag sequences or preamble transmission.

- **HDLC Mode: Transmission with Shared Flags**

If the shared flag option is enabled in HDLC mode via bit CCR1:SFLAG, the first byte of a frame might be replaced by a '7E' flag or 'FF' octet on the transmit line, depending on the interframe time fill selection (bit CCR2:ITF). This leads to a damaged transmit frame.

**Workaround:** It is recommended to disable shared flag transmission by setting bit CCR1:SFLAG = '0'.

*Note: Reception of frames with shared flags is always possible and neither affected by this erratum nor by setting of bit CCR1:SFLAG. Thus networking with other HDLC equipment supporting shared flags is not restricted.*

- **Asynchronous PPP Mode: Reception**

In asynchronous PPP mode the SCC receiver expects a back-to-back stream of ASYNC characters. Once synchronized on the first ASYNC character the receiver expects further octets back-to-back in a fixed scheme determined by the (8, N, 1) character format. The receiver does not synchronize again on subsequent ASYNC characters.

**Workaround:** Do not attempt to configure ASYNC PPP mode, to realize asynchronous PPP mode it is recommended to configure the SCC in ASYNC mode, implementing CRC calculation and character mapping in software. Examples for fast CRC calculation and the character mapping specification are given in RFC 1662 (July 1994) document.

- **Extended Transparent Mode: Minimum Frame Length**

If the frame length in extended transparent mode is programmed to one, an XDU interrupt is generated with all its consequences (transmit SCC stops).

**Workaround:** Frame lengths of 2 or more bytes should be used instead. If a 1-byte frame shall be sent, an idle character should be attached to it.

- **HDLC Automode: Full-duplex Operation**

In HDLC Automode the transmission of an I-frame might be spoiled by simultaneous reception of a frame, sometimes resulting in endless repetition of a byte or in failure of the responding S-frame. Then this channel does not respond autonomously to further reception events.

**Workaround:** None. Do not use full-duplex Automode.

- **Command Execution (CEC) Status Bit Error With External Clocking**

In general the PEB20534 supports external clock gapping in any clock mode in which the internal transmit or receive clock is supplied via the dedicated RxClk and/or TxClk pins. If one of the clocks is externally gapped, the respective receive or transmit block remains in its current static condition until the clock signal is active again. Any command bit in register CMDR (e.g. 'XRES' and 'RRES') effects either the transmit or receive logic and command execution only depends on this block and its clock supply respectively. Nevertheless all commands are forwarded to both transmit and receive block and command execution must be reported internally by both blocks to reset status bit STAR:CEC. Another command is only accepted if 'CEC' bit is cleared.

**Example:** The SCC is configured in clock mode 0a, a clock signal is provided at pin TxClk but pin RxClk is supplied with a constant value (no clock signal or gapped). A transmitter reset command applied by write access to register CMDR will be executed by the transmit block, but status bit 'CEC' remains active afterwards, because the receive block cannot report command execution without clock supply. Any further command will be ignored while 'CEC' bit is active.

**Workaround:** Transmit and receive blocks must be supplied with clock signals in general. Because reset of the command execution (CEC) status bit might be delayed

due to one of the clocks temporarily gapped, 'CEC' status bit must be checked for '0' before writing a command bit.

- **Carrier Auto-detect in HDLC Mode**

The carrier detect (CD) input pin is supposed to enable and disable reception in clock modes 0, 2, 3, 6 and 7. In HDLC/PPP mode this function is not working properly and thus should not be enabled with bit CCR1:CAS.

- **Receiver in Extended Transparent Mode Does Not Initialize**

When attempting to use Extended Transparent Mode (raw bits), it appears as though the receiver does not activate. It unclear whether this is a bug in the PEB20534 or whether it was done by design, but the port that will be receiving in Ext. Trans. Mode must be initialized in clock mode 1 with a clock present on the RT pins. It can then be switched to any other clock mode and will operate correctly.

**Workaround:** If your configuration already uses an external receive clock, simply initialize the card in clock mode 1 (CCR0:CM2..CM0 = '001') with a clock present on the RT pins and then change to whatever clock mode you wish to use. If you do not have an external clock, you can utilize the PROGCLK output pins that are located on the DB25 connector for port 1 at pins 20 and 23. Jumper the PROGCLK pins to the RT pins of your receiving port and initialize the card in clock mode 1.

## TECHNICAL SUPPORT

Commtech provides extensive technical support and application suggestions. Most of the problems that occur with the SuperFASTCOM can be corrected by double-checking the switch positions, your cables and your program. We recommend that you build the loop back plug that is described in the Programming section of this manual. With that plug, you can quickly isolate the problem to the board, cables, or software.

If you still have unresolved questions, use the following procedure to get technical support:

1. Call our Technical Support Staff at (316) 636-1131. They are on duty from 9:00 AM to 5:00 PM Central Time.
2. Ask for technical support for the SuperFASTCOM. Be ready to describe the problem, your computer system, your application, and your software.
3. If necessary, our staff will give you an RMA number (Return Material Authorization). Use this number on the mailing label and in all references to your board. Put the board back in its static bag and in its box. Ship the board back to us as directed.
4. If you prefer, you may FAX a description of the problem to us at (316) 636-1163, or we can be reached on the Internet at "<http://www.commtech-fastcom.com/TechSupport.html>" or by email at "[techsupport@commtech-fastcom.com](mailto:techsupport@commtech-fastcom.com)".

### FASTCOM LIMITED LIFETIME WARRANTY

Commtech's entire FASTCOM product line is covered by a limited lifetime warranty against defects in workmanship. This warranty is available only to the original purchaser and only covers defects in our workmanship. Any FASTCOM board that is returned to Commtech will, at the option of Commtech, be repaired or replaced at no charge -- except for circumstances excluded by this warranty.

A Return Materials Authorization (RMA) number must be obtained from Commtech before a return will be accepted. Please contact us via telephone or email to obtain an RMA number.

You are responsible for shipping charges when you return a FASTCOM board to Commtech. We will pay the shipping charges to send the board back to you if a defect in workmanship is found. However, if no defect in workmanship is found, or the board is not found to be defective, or the any of the following warranty exclusions occur, you will be responsible for shipping charges both ways.

### Warranty Exclusions

This warranty does not cover problems or damage resulting from, but not limited to, the following:

1. Any modification, misuse, abuse, disassembly, misapplication, or unauthorized repair by anyone other than Commtech.
2. Any improper operation, including any use not in accordance with any verbal product instructions or documentation.
3. Connection to an improper voltage supply or ESD damage.
4. Any other cause not related to workmanship.

### Non-Warranty Repairs

We can provide a quote for non-warranty repairs upon request.

If any Commtech product is damaged such that it cannot be repaired, you can return it to Commtech for replacement under our *Non-Repairable Replacement* policy, regardless of the cause of damage. Commtech will replace the unit at 60% of the then-current list price.

### Limitation of Liability

Commtech shall not be liable for any special, incidental, indirect, or consequential damages whatsoever, including but not limited to loss of profits, revenue, or data (whether direct or indirect), or commercial loss for breach of any express or implied warranty on your product even if Commtech has been advised previously of the possibility of such damages. Commtech's liability, in any case, shall not exceed the original product purchase price.

## APPENDIX A

# INFINEON 20534

## TECHNICAL DATA