

# ***FASTCOM<sup>®</sup> ADAPTERS***

## ***FASTCOM<sup>®</sup>: 422/4-104-ET***

**Four Channel RS-422/RS-485 Asynchronous  
Extended Temperature Interface for PC/104 Bus  
Hardware Reference Manual**



**COMMTECH, INC.**

**9011 E 37th St N  
Wichita KS USA  
67226-2006**





# COMMTECH

9011 E. 37TH STREET N.  
WICHITA, KANSAS 67226-2006

(316) 636-1131

FAX (316) 636-1163

<http://www.commtech-fastcom.com/>

COPYRIGHT (C) 2003, 2006, 2010

All rights reserved, including those to reproduce this document or parts thereof in any form without permission in writing from Commtech, Inc.

FASTCOM and the "Alpha Lemur" are registered trademarks of Commtech, Inc.

IBM is a registered trademark of International Business Machines Corporation.

Microsoft is a registered trademark of Microsoft Corporation.

WINDOWS is a trademark of Microsoft Corporation.





## REVISION NOTES

<u>REVISION</u>	<u>PAGE NUMBER</u>	<u>CHANGES MADE</u>
1.0	All	Document created
1.1	16	Changed warranty period to lifetime
1.2	7	Added Windows mode description
1.3	17	Changed warranty to limited lifetime

# CONTENTS

INTRODUCTION	
<a href="#">Description / Block Diagram</a> .....	1
<a href="#">Specifications / Features</a> .....	2
<a href="#">Board Layout</a> .....	3
INSTALLATION	
<a href="#">Factory Switch Settings</a> .....	4
<a href="#">Installing the Board</a> .....	4
<a href="#">Testing the Installation</a> .....	5
OPERATING MODES	
<a href="#">Windows Mode</a> .....	7
<a href="#">Switch Descriptions</a>	
<a href="#">Base Address</a> .....	8
<a href="#">IRQ Select</a> .....	9
<a href="#">Interrupt Sharing</a> .....	9
<a href="#">Operating Mode</a> .....	10
<a href="#">RS-422 / RS-485</a> .....	12
<a href="#">Termination Resistance</a> .....	13
<a href="#">DB9 Description</a> .....	14
<a href="#">Cable</a> .....	14
<a href="#">40 Pin Latch-Lock Connector Pin-Out</a> .....	16
<a href="#">TECHNICAL SUPPORT</a> .....	17
APPENDIX A	
<a href="#">I/O Address Settings</a> .....	18
APPENDIX B	
<a href="#">16C864 UART Technical Data</a> .....	23



## INTRODUCTION

The new FASTCOM: 422/4-104-ET adapter is the fastest (1.5 Mbps), most advanced, four-port RS-422 asynchronous adapter in the industry. Primarily designed for commercial, industrial, and OEM applications, the FASTCOM: 422/4-104-ET features four discrete RS-422 channels, complete with RTS and CTS flow control signals, and is specified to operate in the extended temperature range.

The advanced UART on the FASTCOM: 422/4-104-ET features full compatibility with standard 16C550 and 16C650 UARTs, but provides **extraordinary 128-byte receive and transmit FIFOs for buffering**. This buffering is extremely important when working with RS-422/RS-485 communications within high overhead operating systems such as Windows NT and Windows 95/98. The extra-deep FIFOs prevent data loss due to overrun and dramatically improve data throughput in all applications. **The advanced UART on the FASTCOM: 422/4-104-ET is capable of all standard baud rates plus a high-speed mode capable of up to an amazing 1.5 Mbps (crystal change required).**

The Fastcom CD contains software and information for DOS, Linux, Windows 95/98, Windows NT, and Windows 2000, and is compatible with Windows XP. The "shared interrupt" design and user selectable address allow the installation of multiple FASTCOM: 422/4-104-ET cards in the same system.

The FASTCOM: 422 family of adapters includes the dual channel FASTCOM: 422/2-104, the single channel FASTCOM: 422/1-ISA and the dual channel FASTCOM: 422/2-ISA for the ISA bus, and the fully isolated FASTCOM: IG422/1-ISA. The FASTCOM: 422/2-PCI, the FASTCOM: 422/4-PCI, and the FASTCOM: IG422/1-PCI are available for PCI bus systems.

The following is the basic structure of the FASTCOM: 422/4-104-ET:

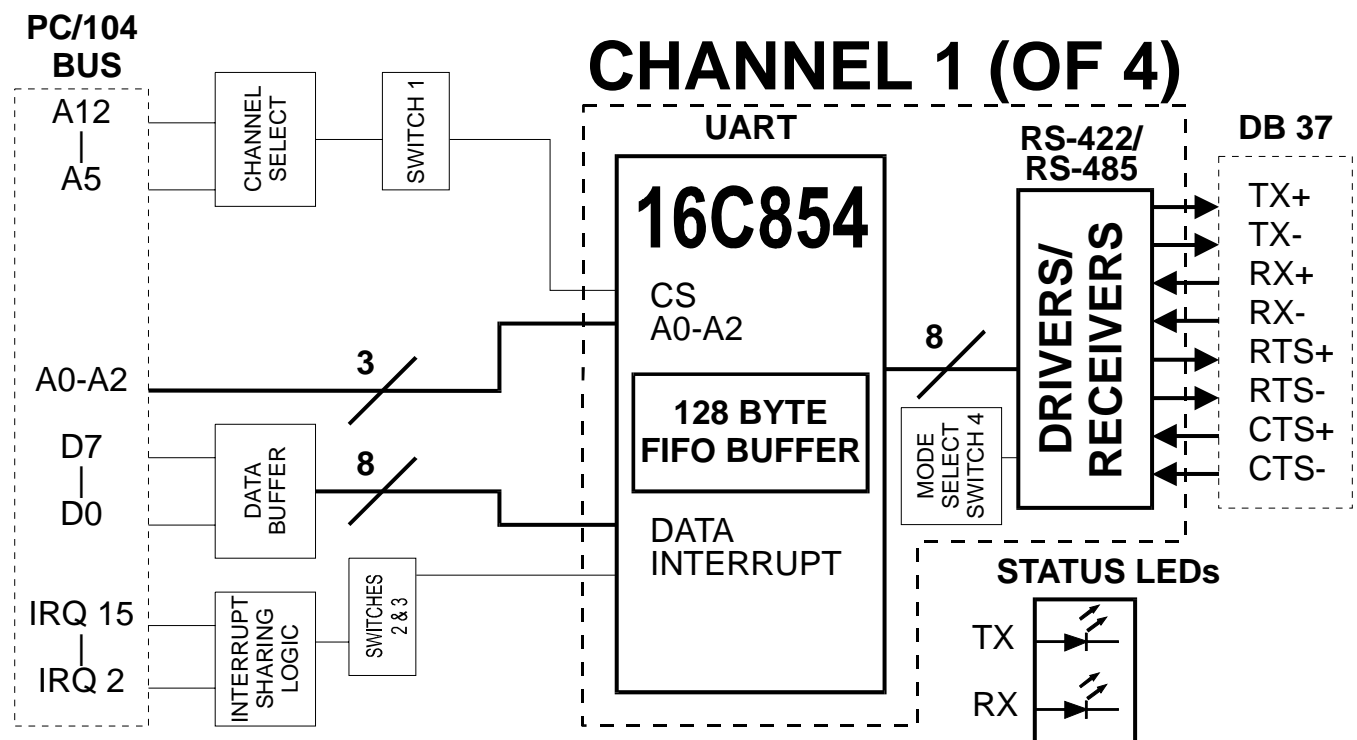

## SPECIFICATIONS:

UART:	16C864
BAUD RANGE:	Up to 1.5 Mbaud *
BUFFERING:	Transmit - 128 bytes Receive - 128 bytes
INTERFACE:	RS-422/RS-485C 40 pin latch lock pin header
SIGNALS:	TX, RX, RTS, CTS
PROTOCOL:	Asynchronous
BUS:	PC/104
POWER REQUIREMENTS:	+5 500mA (typical)
ENVIRONMENT:	
Storage Temperature Range:	-55 C to +125 C
Operating Temperature Range:	-40 C to +85 C
Humidity:	0 to 90% (non-condensing)

## FEATURES:

### **Fastcom: 422/4-104-ET**

Four independent RS-422 / RS-485 channels  
Transmit / Receive status LEDs for each channel  
TX, RX, RTS, CTS signals for each channel  
Excellent noise immunity

### **Extended temperature components**

Designed for operation in more extreme environments

### **Address mode**

WINDOWS MODE: Ports are configured as COM1, COM2, COM3, and COM4  
FASTCOM MODE: Ports are assigned address and IRQ by the user

### **RS-485**

Up to 32 stations on same "twisted-pair" network  
RTS control of the line driver

### **High performance 16C864 UART**

Standard on the Fastcom: 422/4-104-ET, *no extra charge*  
High throughput, full compatibility, higher speed

### **Documentation, software, and drivers included on CD**

### **Made in Wichita, Kansas, USA**

\* A clock change is required to achieve baud rates higher than 115.2 Kbaud.

# FASTCOM: 422/4-104-ET

## BOARD LAYOUT ILLUSTRATION

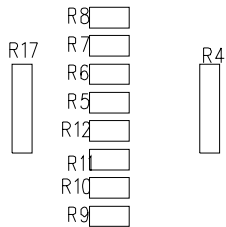
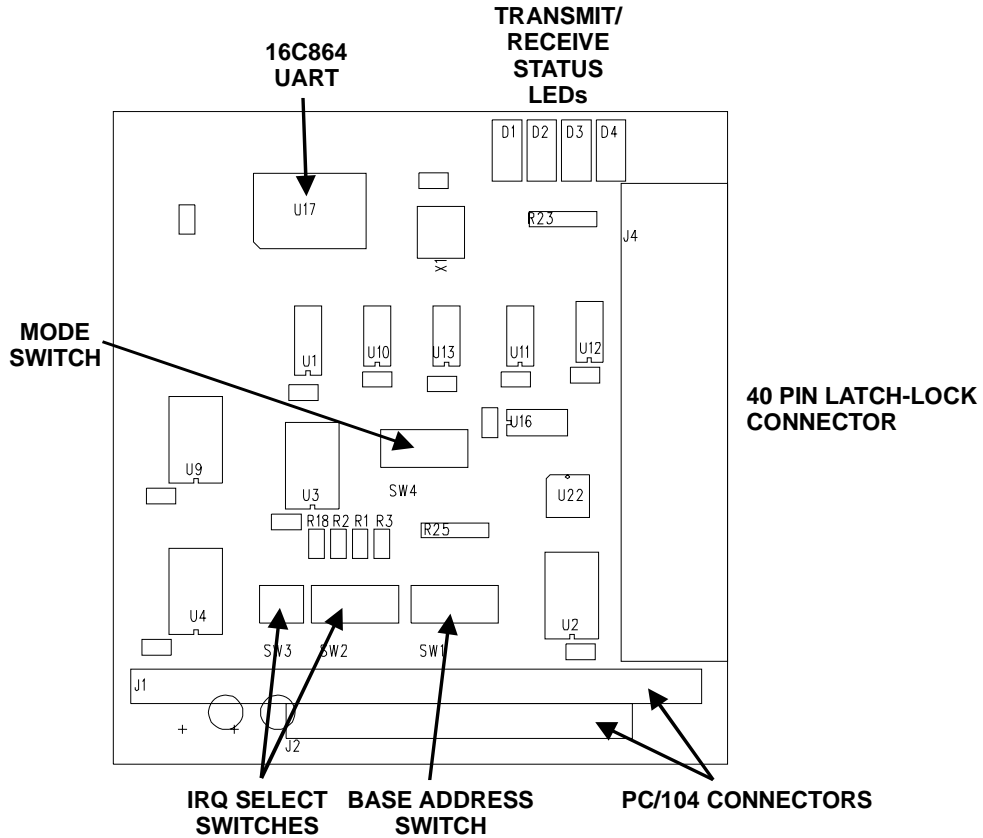

**ON BACK OF BOARD**

### TERMINATION REFERENCE:

<u>REF</u>	<u>SIGNAL</u>
R12	RX 1
R11	RX 2
R10	RX 3
R9	RX 4
R8	CTS 1
R7	CTS 2
R6	CTS 3
R5	CTS 4

### LED INDICATORS:

RED - TRANSMIT ACTIVE  
YELLOW - RECEIVE ACTIVE

## PACKING LIST

FASTCOM: 422/4-104-ET CARD  
CABLE ASSEMBLY  
FASTCOM CD

If an omission has been made, please call technical support for a replacement.

## INSTALLATION

**Important:** Observe Electrostatic Discharge (ESD) precautions when handling the FASTCOM: 422/4-104-ET board.

### FACTORY SWITCH SETTINGS

NOTE: See the [Board Layout Illustration](#) for the location of switches on the board.

ADDRESS (SW1) = 280H

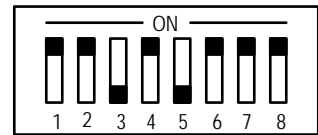

IRQ (SW3 SW2) = 5 (NOT SHARED)

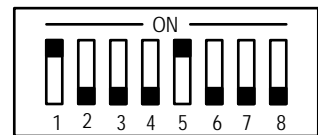
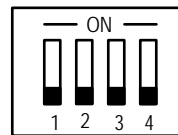

MODE (SW4) - CTS HANDSHAKING DISABLED  
RS-485 DRIVER CONTROL DISABLED

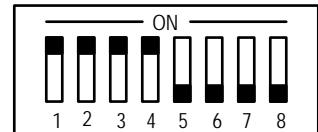

### INSTALLING THE FASTCOM: 422/4-104-ET IN THE PC/104 STACK

1. Unpack the FASTCOM: 422/4-104-ET. Keep the box and static bag for warranty repair returns.
2. Check the switches to be sure that they are set for the mode you want.
3. Re-install the cover on your PC/104 stack.

## TESTING THE INSTALLATION

To fully test the installation of your FASTCOM: 422/4-104-ET, you will need to build a “loop back plug”. Materials needed are a DB9 male plug, solder cup style, and a few short pieces of 20 or 24 AWG stranded wire. Jumper the pins together on the DB9 as illustrated below:

4	TX+
5	TX-
8	RX+
9	RX-

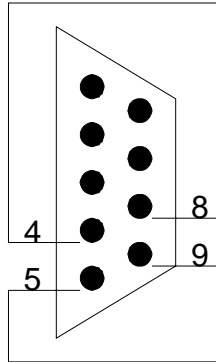

### TESTING YOUR FASTCOM ASYNC PC/104 PORT IN WINDOWS

These instructions assume that you have already installed the card and have followed the installation instructions. In NT, the ports should be visible in the Control Panel ->Ports applet. In Windows 98, the ports should show up in Control Panel in the System icon's Device Manager. The port installation instructions can be found on the disk in:

For Windows98	D:\Fastcom_Disks\Smart14\Windows\W98\howto.txt
For Windows NT	D:\Fastcom_Disks\Smart14\Windows\NT\howto.txt
For Windows 2000/XP	D:\Fastcom_disks\Smart14\WINDOWS\W2000\W2kserialInstall.txt
For Linux	D:\Fastcom_disks\Smart14\howto.txt

1. Install the loopback plug on the port to test.
2. Find and run the TTY.EXE program.  
From the Start menu, choose Run, browse to and select  
D:\Fastcom\_Disks\Smart14\windows\win32\tty\tty.exe.  
Select TTY.EXE and click open.  
Click OK to run the TTY program.
3. From the menu bar on the TTY program, select Settings.  
Select the port to test (e.g., COM5)  
Uncheck all of the flow checkboxes (DTR/DSR, RTS/CTS, XON/XOFF).  
Click OK.
4. From the TTY main menu bar select Action, then Connect.
5. At this point you should see a blinking cursor in the upper left corner of the TTY window. Try to type on the keyboard; you should see the characters that you are typing in the TTY window. If you see what you type, the port is passing the loopback, and is installed and functioning correctly.

If you get a “Connection Failed” message box when you try the Action ->Connect sequence, some possible causes are:

1. Incorrect or mismatched address or IRQ settings between what the switches on the board are set to and what is set up in the driver. You can check the driver settings in NT using Control Panel ->Ports ->COMx ->Advanced. In Windows 98, you need to look in Control Panel ->System, Device Manager tab, Ports (COM & LPT), select the COM#, click the Properties button, then the Resources tab. Check the address switch settings using the table in the back of the manual. Realize that multiport cards addresses are

sequential (if set to base address of 0x280, then the addresses for the four ports will be 0x280, 0x288, 0x290, and 0x298).

If you are using NT, you can run NT Diagnostics (from the Start button, choose Programs ->Administrative Tools ->Windows NT Diagnostics) to verify that there is not another device trying to use the address range or IRQ. The Resources tab in Windows 95 (location listed above) should indicate a resource conflict if another device is using the same I/O range or IRQ. Even if you don't see a listed conflict, try a different address/IRQ combination if all of the settings are matched and it still doesn't work.

If you have tried a couple of different address/IRQ combinations without success, you might try using an Ohm meter or continuity tester to verify that the switch positions are actually what they are set to. The switch positions that are ON should be closed (about 0 ohms); the ones that are OFF should be open (not 0 Ohms). Sometimes the dip switches will get stuck in either the on or off position irrespective of the position of the slide. If this happens, try toggling the stuck position on and off a few times and re-check it.

2. In NT, if multiple ports are opened (running more than one instance of TTY), the ports are using the same IRQ, and the PermitShare registry entry is 0, the second port to be opened will fail. Use the registry editor and expand HKEY\_LOCAL\_MACHINE ->SYSTEM ->CurrentControlSet ->Services ->Serial, change the PermitShare value from 0 to 1, reboot, and run the test again.

If you get to the blinking cursor stage, but do not see what you type with the loopback plug installed, some possible reasons are:

1. Incorrect/faulty loopback plug construction or a bad connection.
2. If you have a RS-422/485 board, check to make sure that the 485 mode is disabled. The loopback test should be run in RS-422 mode (the RS-485 driver control switches should be in the OFF position).
3. The RTS/CTS flow control is checked and there is not a RTS->CTS loopback, or the CTS disabled switch is OFF. If you enable flow control, you must allow CTS to be active in order for the driver to transmit data. Either disable flow control, or wire the RTS->CTS (and possibly DTR->DSR) loop and try the test again.
4. Check to make sure that the loopback plug is on the correct port/cable (or that the correct port is selected in the settings dialog).
5. If you type a character and the cursor stops blinking for a long time and the PC/TTY window stops responding (appears locked up) but returns to a blinking cursor state after a few minutes, this is a good indication that the interrupt setting on the card is not the same as the interrupt setting of the port in Windows. Re-verify that the IRQ setting on the board switches and in Control Panel are the same.

## FASTCOM: 422/4-104-ET OPERATING MODES

The FASTCOM: 422/4-104-ET has two modes of operation: the FASTCOM MODE and the WINDOWS MODE. The operating mode is selected by the setting of position 6 of switch 2. In the ON position, the WINDOWS MODE is selected. In the OFF position, the FASTCOM MODE is selected. In the FASTCOM MODE, the board address/IRQ configuration is determined by setting Switches 1, 2, and 3. In the WINDOWS MODE, each channel is assigned an address/IRQ level that provides "drop-in" compatibility with WINDOWS/DOS applications.

### WINDOWS MODE

If the WINDOWS MODE is selected, the base address switch (Switch 1) is overridden. Switch 2, Position 6 should be set to ON, and all other positions should be set to OFF. All positions on Switch 3 should be set to OFF. The Address/IRQ for each channel is as follows in WINDOWS MODE:

<u>CHANNEL</u>	<u>ADDRESS</u>	<u>IRQ</u>	<u>NAME</u>
CHANNEL 1	3F8H	4	COM1:
CHANNEL 2	2F8H	3	COM2:
CHANNEL 3	3E8H	4	COM3:
CHANNEL 4	2E8H	3	COM4:

**IMPORTANT:** Be sure that Switch 2, Position 6 is ON and all other positions on Switches 2 and 3 are OFF.

### FASTCOM MODE SWITCH DESCRIPTIONS

There are four dip switches on the FASTCOM: 422/4-104-ET labeled SW1, SW2, SW3, and SW4 (See Board Layout Illustration for location). Switch 1 (labeled Base Address) is used to set the I/O address of the FASTCOM: 422/4-104-ET board. Switch 2 (labeled IRQ) serves three functions: it selects the IRQ level for the board, is used to enable/disable interrupt sharing, and selects the operating mode for the board. Switch 3 is used to select upper level IRQ settings. Switch 4 is used to control the RS-422/485 operating modes.

## SWITCH DESCRIPTIONS

There are four dip switches on the FASTCOM: 422/4-104-ET, labeled SW1 through SW4 (See [Board Layout Illustration](#) for location). Switch 1 (labeled BASE ADDRESS) is used to set the base I/O address of the FASTCOM: 422/4-104-ET board. Switches 2 and 3 (labeled IRQ SELECT) serve two functions: they select the IRQ level and are used to enable/disable interrupt sharing. Switch 4 (labeled MODE SWITCH) selects either RS-422 or RS-485 mode and enables/disables handshaking for each channel.

### SWITCH 1, BASE ADDRESS

Switch 1 decodes the PC/104 address lines as follows:

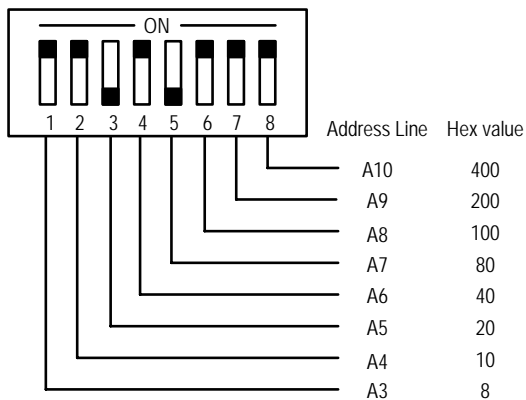

Address lines A5 through A12 are decoded by the setting of SW1 and set the address of each channel of the FASTCOM: 422/4-104-ET. Address lines A3 and A4 are used on the board to select which port (1, 2, 3, or 4) you want to use. Address lines A0, A1, and A2 are used to select the registers within the UARTs.

The above diagram illustrates a base address of 280 Hex. Note that when a switch is **ON** it represents a "0" in the corresponding bit position (not a "1" as you might expect). Also, a switch that is OFF represents a "1" in the corresponding bit position. If you would like to know why this is reversed, read a technical data sheet for the address decoder chip, a 74LS682.

So, the SW1 diagram can be decoded as follows:

A12	A11	A10	A9	A8	A7	A6	A5
0	0	0	1	0	1	0	0

You can determine the base I/O address of the board by adding the Hex values for each address line that is set to a "1". In the illustration, address lines A7 and A9 are set to "1". So, add the hex value of A9 (200H) and A7 (80H), and the result is the base I/O address (200H + 80H = 280H).

Switch 1 is referred to as the Base Address switch because it marks the beginning address of the first channel on the FASTCOM: 422/4-104-ET board. The other channels are addressed as an offset to the first channel. For example, if we set the Base Address to 280H, note the address of each channel:

CHANNEL	BASE	OFFSET	ADDRESS
1	280H	+ 0H	= 280H
2	280H	+ 8H	= 288H
3	280H	+ 10H	= 290H
4	280H	+ 18H	= 298H

We have provided a comprehensive guide to setting the address switch in Appendix A.

Please note that not all of the I/O address space in a PC/104 stack is available for your use. If you wish to select an address other than the default, refer to [Appendix A, I/O Address Usage Table](#), and select an address that does not conflict with devices installed in your PC/104. Keep in mind that the FASTCOM: 422/4-104-ET requires 8 contiguous bytes of address space per channel, for a total of 32 contiguous bytes.

If you want to install more than one FASTCOM: 422/4-104-ET board in your computer, be sure to set each to a unique I/O address. We recommend the following addresses for a multi-board system:

	<u>BASE ADDRESS</u>
FASTCOM: 422/4-104-ET BOARD 1	280H
FASTCOM: 422/4-104-ET BOARD 2	300H
FASTCOM: 422/4-104-ET BOARD 3	380H
FASTCOM: 422/4-104-ET BOARD 4	400H

Remember that a single IRQ level can be shared between multiple FASTCOM: 422/4-104-ET boards in a PC/104 stack.

## SWITCHES 2 and 3, INTERRUPT SELECT

Switch 2 serves three functions: it selects the IRQ level for the FASTCOM: 422/4-104-ET, enables/disables interrupt sharing, and selects the operating mode for the board. Switch 3 selects upper level IRQ settings.

The following illustrates the IRQ select switches on the FASTCOM: 422/4-104-ET:

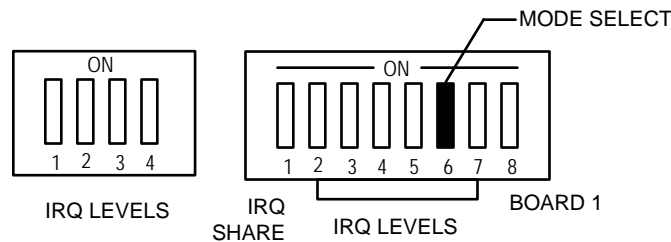

Positions 2 through 5 and 7 select the IRQ level for the FASTCOM: 422/4-104-ET. Select only 1 IRQ level at a time. Position 6 selects either WINDOWS or FASTCOM mode.

<u>SWITCH 2</u>			<u>SWITCH 3</u>		
<u>SWITCH POSITION</u>	<u>PC/AT/386 IRQ</u>	<u>Assigned</u>	<u>SWITCH POSITION</u>	<u>IRQ LEVEL</u>	<u>Assigned</u>
2	9	UNUSED	1	10	UNUSED
3	3	COM2	2	11	UNUSED
4	4	COM1	3	12	UNUSED
5	5	UNUSED (LPT2)	4	15	UNUSED
6	6	USED FOR DOS / WINDOWS MODE SELECT			
7	7	LPT1			

You can use any IRQ that is not assigned to a device installed in your PC/104.

## INTERRUPT SHARING

An important feature of the FASTCOM: 422/4-104-ET is its ability to share one IRQ with several other FASTCOM boards in the same computer. This is important because there are very few unassigned IRQs in the PC/104.

Switch 2 positions 1 and 8 control the interrupt sharing circuit on the FASTCOM: 422/4-104-ET. Position 1 Enables interrupt sharing in the OFF position and Disables sharing in the ON position. Position 8 is called the "Board 1" switch. In the interrupt sharing mode, this switch must be ON for the first FASTCOM: 422/4-104-ET board in your system, and OFF for all other FASTCOM: 422/4-104-ET boards.

**SWITCH 2**  
**POSITION**

<u>1</u>	<u>8</u>	
ON	OFF	Disables IRQ sharing
OFF	ON	Enables IRQ sharing, first board
OFF	OFF	Enables IRQ sharing, second board

For example, let's assume that you want to set two FASTCOM: 422/4-104-ET boards to share IRQ 5. Set Switches 2 and 3 as follows for the first board:



For the second board, set Switches 2 and 3 as follows:



For any additional FASTCOM: 422/4-104-ET board that shares IRQ 5, set Switches 2 and 3 the same as the first board.

### SWITCH 4, OPERATING MODE

The FASTCOM: 422/4-104-ET has two modes of operation selected by Switch 4: the RS-422 mode and the RS-485 mode.

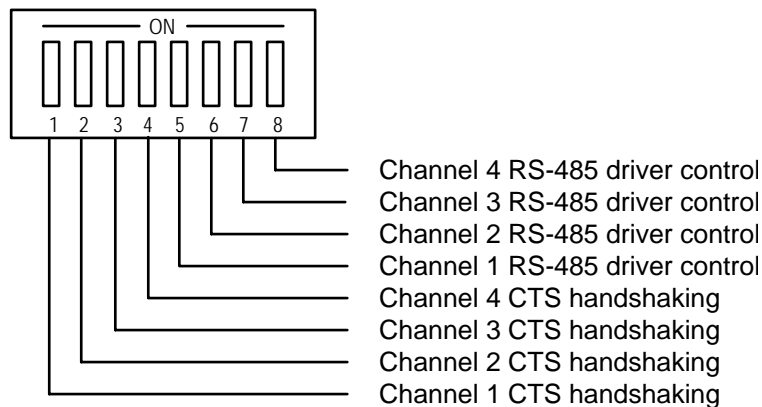

Switch positions 1, 2, 3, and 4 enable or disable CTS handshaking for each channel. When ON, CTS handshaking is disabled; when OFF, CTS handshaking is enabled. In RS-485 mode, CTS handshaking is usually disabled.



Switch positions 5, 6, 7, and 8 enable or disable RS-485 driver control for each channel. When ON, the transmit driver enable line is controlled by the state of the RTS line of the UART. The RTS line may be controlled directly by your software by writing to the UART Modem Control Register (See [Appendix B](#)). Setting the RTS bit to 1 in the Modem Control Register will enable the drivers; setting it to 0 will disable the drivers.



## RS-422/RS485

Most engineers have worked with RS-232 devices at least once in their career. If you have never worked with RS-422 or RS-485 devices, you will be pleased to know that working with the FASTCOM: 422/4-104-ET is not much different from working with an RS-232 device.

The RS-422 standard was developed to correct some of the deficiencies of RS-232. In commercial and industrial applications, RS-232 has some significant problems. First, the cable length between RS-232 devices must be short (usually less than 50 feet at 9600 Baud). Second, many RS-232 errors are the result of cables picking up normal industrial electrical noises, such as fluorescent lights, motors, transformers, and other EMF sources. Third, RS-232 data rates are functionally limited to 19.2K Baud. On the other hand, the newer RS-422 standard makes cable lengths up to 5000 feet possible and is highly immune to most industrial noises. Data rates are also improved - the FASTCOM: 422/4-104-ET features data rates up to 1 Meg Baud. These improvements were made possible by differentially driving and receiving the data as opposed to the single ended method employed by the RS-232 standard. With the RS-422 standard, the transmit signal (TX in RS-232) is a differential signal consisting of TX+ and TX-, the receive signal (RX in RS-232) consists of RX+ and RX-.

Another drawback of RS-232 is that more than two devices cannot share a single cable. This is also true of RS-422, and that's why the RS-485 standard was developed. RS-485 offers all of the benefits of RS-422 and also allows multiple units (up to 32) to share the same twisted pair. RS-485 is often referred to as a "multi-drop" or "two-wire, half duplex" network because the drivers (transmitters) and receivers share the same two lines. In fact, up to 32 stations can share the same "twisted pair". In order for an RS-485 system to work, only one driver (transmitter) can occupy the network at a time. This means that each station on the network must control the enabling/disabling of its drivers in order to avoid network conflicts. If two drivers engage the network at the same time, data from both will be corrupted. In RS-485 mode, the receivers are always enabled.

For a more detailed description of RS-422 and RS-485, we recommend the following references:

LINEAR AND INTERFACE CIRCUITS APPLICATIONS, Volume 2: Line Circuits, Display Drivers. By D.E. Pippenger and E. J. Tobaben. Published 1985 by Texas Instruments. ISBN-0-89512-185-9

Note: This book may be difficult to find in a bookstore. The best place to get it is directly from Texas Instruments or from one their component dealers. Publication # SLYA002.

"Driver/Receiver Family Extends Data-Link Performance", ELECTRONIC PRODUCTS, January 15, 1985. By Dale Pippenger and Joe Miller.

# TERMINATION RESISTANCE

In both the RS-422 and the RS-485 mode, the receiver end of the cable between two stations must be terminated with a resistor equal to the characteristic impedance of the wire. This is to prevent signal reflections in the wire and to improve noise rejection. However, **you do not need to add a terminator resistor to your cables when you use the FASTCOM: 422/4-104-ET. The termination resistance is built in.** We have installed a terminator resistor for each receiver: between each RX+ and RX-, and between CTS+ and CTS- for each channel.

If you are using the FASTCOM: 422/4-104-ET in a multi-drop network, the termination resistor should be removed from all units except the first and last (see the RS-485 illustration below). Call for technical support if you need to modify the resistor.

Observe the resistors in the following illustration and remember that they are built into the FASTCOM: 422/4-104-ET:

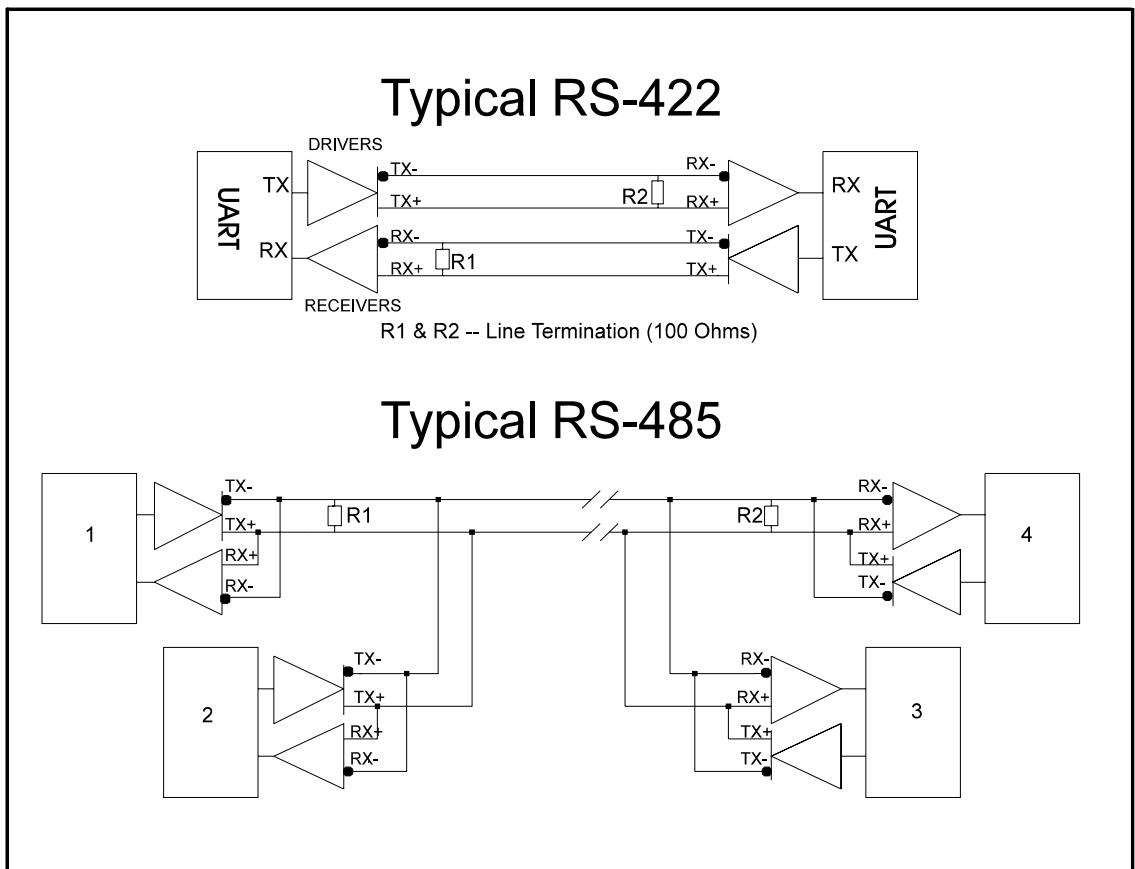

## TERMINATION REFERENCE:

REF	SIGNAL
R12	RX 1
R11	RX 2
R10	RX 3
R9	RX 4
R8	CTS 1
R7	CTS 2
R6	CTS 3
R5	CTS 4

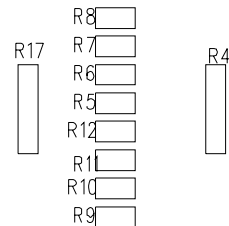

**ON BACK OF BOARD**

## DB9 PIN DESCRIPTION

The FASTCOM: 422/4-104-ET features four RS-422/RS-485 channels, which are accessed through DB9 connectors connected to the board via ribbon cable.

The following is a pin description of the DB9 connectors:

PIN NO.	SIGNAL NAME	DIRECTION
1	SIGNAL GROUND (GND)	GROUND
2	READY TO SEND + (RTS+)	OUTPUT
3	READY TO SEND – (RTS-)	OUTPUT
4	TRANSMIT DATA + (TX+)	OUTPUT
5	TRANSMIT DATA – (TX-)	OUTPUT
6	CLEAR TO SEND – (CTS-)	INPUT
7	CLEAR TO SEND + (CTS+)	INPUT
8	RECEIVE DATA + (RX+)	INPUT
9	RECEIVE DATA – (RX-)	INPUT

## CABLE

### RS-422

We recommend using vinyl jacketed, shielded, multiple twisted pair cable (24 AWG wire) for use with the FASTCOM: 422/4-104-ET. The following cable illustration shows how to connect two RS-422 devices. Note that the CTS/RTS lines can be eliminated by disabling handshaking.

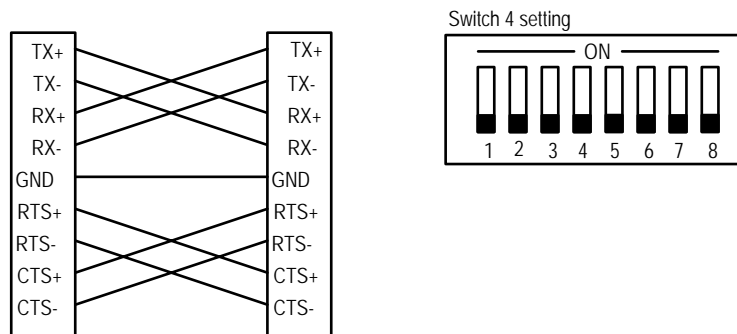

Note: If you are not connecting the FASTCOM: 422/4-104-ET to another FASTCOM: 422/4-104-ET, you should make sure that the line is terminated properly by the other device. Also note that other RS-422 devices may not use the same pin descriptions.

## RS-485

The following cable illustration shows four RS-485 devices sharing the same twisted pair:

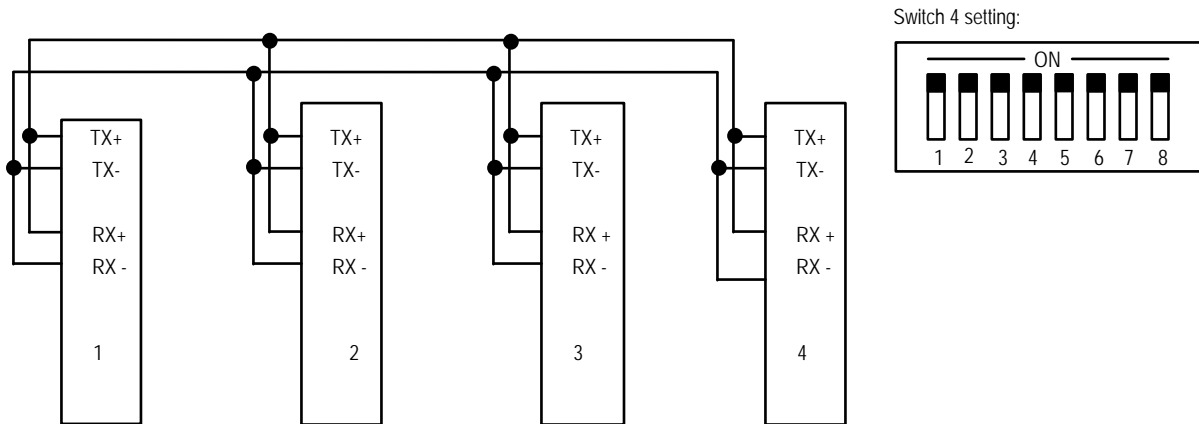

Note: The termination resistors from Station #2 and Station #3 have been removed.

Not all RS-422 devices feature RS-485 compatibility. Only RS-485 devices can be connected to the RS-485 network.

## 40 PIN LATCH-LOCK CONNECTOR PIN-OUT

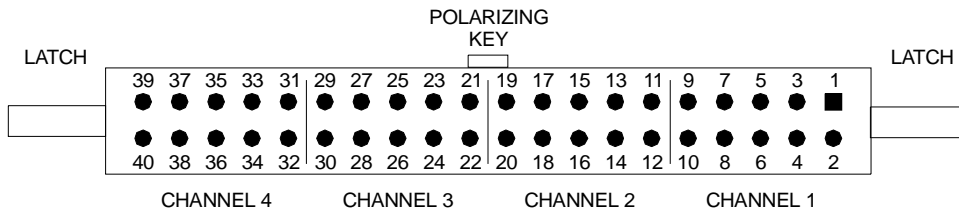

PIN #	SIGNAL NAME	PIN #	SIGNAL NAME
1	GND	21	GND
2	CTS-	22	CTS-
3	RTS+	23	RTS+
4	CTS+	24	CTS+
5	RTS-	25	RTS-
6	RXD+	26	RXD+
7	TXD+	27	TXD+
8	RXD-	28	RXD-
9	TXD-	29	TXD-
10	GND	30	GND
11	GND	31	GND
12	CTS-	32	CTS-
13	RTS+	33	RTS+
14	CTS+	34	CTS+
15	RTS-	35	RTS-
16	RXD+	36	RXD+
17	TXD+	37	TXD+
18	RXD-	38	RXD-
19	TXD-	39	TXD-
20	GND	40	GND

## TECHNICAL SUPPORT

Commtech provides extensive technical support and application suggestions. Most of the problems that occur with the FASTCOM: 422/4-104-ET can be corrected by double-checking the switch positions, your cables and your program. We recommend that you build the loop back plug that is described in the Programming section of this manual. With that plug, you can quickly isolate the problem to the board, cables, or software.

If you still have unresolved questions, use the following procedure to get technical support:

1. Call our Technical Support Staff at (316) 636-1131. They are on duty from 9:00 AM to 5:00 PM Central Time.
2. Ask for technical support for the FASTCOM: 422/4-104-ET. Be ready to describe the problem, your computer system, your application, and your software.
3. If necessary, our staff will give you an RMA number (Return Material Authorization). Use this number on the mailing label and in all references to your board. Put the board back in its static bag and in its box. Ship the board back to us as directed.
4. If you prefer, you may FAX a description of the problem to us at (316) 636-1163, or we can be reached on the Internet at "<http://www.commtech-fastcom.com/TechSupport.html>" or by email at "[techsupport@commtech-fastcom.com](mailto:techsupport@commtech-fastcom.com)".

### FASTCOM LIMITED LIFETIME WARRANTY

Commtech's entire FASTCOM product line is covered by a limited lifetime warranty against defects in workmanship. This warranty is available only to the original purchaser and only covers defects in our workmanship. Any FASTCOM board that is returned to Commtech will, at the option of Commtech, be repaired or replaced at no charge -- except for circumstances excluded by this warranty.

A Return Materials Authorization (RMA) number must be obtained from Commtech before a return will be accepted. Please contact us via telephone or email to obtain an RMA number.

You are responsible for shipping charges when you return a FASTCOM board to Commtech. We will pay the shipping charges to send the board back to you if a defect in workmanship is found. However, if no defect in workmanship is found, or the board is not found to be defective, or the any of the following warranty exclusions occur, you will be responsible for shipping charges both ways.

### Warranty Exclusions

This warranty does not cover problems or damage resulting from, but not limited to, the following:

1. Any modification, misuse, abuse, disassembly, misapplication, or unauthorized repair by anyone other than Commtech.
2. Any improper operation, including any use not in accordance with any verbal product instructions or documentation.
3. Connection to an improper voltage supply or ESD damage.
4. Any other cause not related to workmanship.

### Non-Warranty Repairs

We can provide a quote for non-warranty repairs upon request.

If any Commtech product is damaged such that it cannot be repaired, you can return it to Commtech for replacement under our *Non-Repairable Replacement* policy, regardless of the cause of damage. Commtech will replace the unit at 60% of the then-current list price.

### Limitation of Liability

Commtech shall not be liable for any special, incidental, indirect, or consequential damages whatsoever, including but not limited to loss of profits, revenue, or data (whether direct or indirect), or commercial loss for breach of any express or implied warranty on your product even if Commtech has been advised previously of the possibility of such damages. Commtech's liability, in any case, shall not exceed the original product purchase price.

## APPENDIX A

### I/O ADDRESS SETTINGS

Each channel of the Fastcom: 422/4-104-ET requires 8 contiguous bytes of address space for a total of 32 contiguous bytes. The following are I/O addresses and devices that are typically assigned to them. You may use any I/O address that is not used by a device installed in your system.

<u>HEX RANGE</u>	<u>DEVICE</u>
000 - 01F	DMA CONTROLLER 1
020 - 03F	INTERRUPT CONTROLLER 1
040 - 05F	TIMER
060 - 06F	KEYBOARD
070 - 07F	REAL TIME CLOCK
080 - 09F	DMA PAGE REGISTER
0A0 - 0BF	INTERRUPT CONTROLLER 2
0C0 - 0DF	DMA CONTROLLER 2
0E0 - 0EF	<b>UNUSED</b> (16 contiguous bytes)
0F0 - 0FF	MATH COPROCESSOR
100 - 1EF	<b>UNUSED</b> (240 contiguous bytes)
1F0 - 1F8	FIXED DISK
1F9 - 1FF	<b>UNUSED</b> (7 contiguous bytes)
200 - 207	GAME PORT
208 - 20B	<b>UNUSED</b> (4 contiguous bytes)
20C - 20D	RESERVED
20E - 21E	<b>UNUSED</b> (16 contiguous bytes)
21F	RESERVED
220 - 22F	<b>UNUSED</b> (16 contiguous bytes)
230 - 23F	BUS MOUSE
240 - 277	<b>UNUSED</b> (56 contiguous bytes)
278 - 27F	PARALLEL PORT (SECONDARY)
280 - 2AF	<b>UNUSED</b> (48 contiguous bytes)
2B0 - 2DF	ALTERNATE EGA
2E0 - 2E7	<b>UNUSED</b> (8 contiguous bytes)
<b>2E8 - 2EF</b>	<b>COM4:</b>
2F0 - 2F7	<b>UNUSED</b> (8 contiguous bytes)
<b>2F8 - 2FF</b>	<b>COM2:</b>
300 - 31F	<b>UNUSED</b> (32 contiguous bytes)
320 - 32F	DISK CONTROLLER
330 - 35F	<b>UNUSED</b> (48 contiguous bytes)
360 - 36F	NETWORK CARD
370 - 377	<b>UNUSED</b> (8 contiguous bytes)
378 - 37F	PARALLEL PORT (PRIMARY)
380 - 38F	<b>UNUSED</b> (16 contiguous bytes)
390 - 393	CLUSTER
394 - 3AF	<b>UNUSED</b> (28 contiguous bytes)
3B0 - 3BF	MONOCHROME DISPLAY / PARALLEL PORT (TERTIARY)
3C0 - 3CF	EGA
3D0 - 3DF	CGA
3E0 - 3E7	<b>UNUSED</b> (8 contiguous bytes)
<b>3E8 - 3EF</b>	<b>COM3:</b>
3F0 - 3F7	DISKETTE CONTROLLER
<b>3F8 - 3FF</b>	<b>COM1:</b>



Hex (Decimal)	1	2	3	4	5	6	7	8
800h (2048)	1	1	1	1	1	1	0	1
820h (2080)	0	1	1	1	1	1	0	1
840h (2112)	1	0	1	1	1	1	0	1
860h (2144)	0	0	1	1	1	1	0	1
880h (2176)	1	1	0	1	1	1	0	1
8a0h (2208)	0	1	0	1	1	1	0	1
8c0h (2240)	1	0	0	1	1	1	0	1
8e0h (2272)	0	0	0	1	1	1	0	1
900h (2304)	1	1	1	0	1	1	0	1
920h (2336)	0	1	1	0	1	1	0	1
940h (2368)	1	0	1	0	1	1	0	1
960h (2400)	0	0	1	0	1	1	0	1
980h (2432)	1	1	0	0	1	1	0	1
9a0h (2464)	0	1	0	0	1	1	0	1
9c0h (2496)	1	0	0	0	1	1	0	1
9e0h (2528)	0	0	0	0	1	1	0	1
a00h (2560)	1	1	1	1	0	1	0	1
a20h (2592)	0	1	1	1	0	1	0	1
a40h (2624)	1	0	1	1	0	1	0	1
a60h (2656)	0	0	1	1	0	1	0	1
a80h (2688)	1	1	0	1	0	1	0	1
aa0h (2720)	0	1	0	1	0	1	0	1
ac0h (2752)	1	0	0	1	0	1	0	1
ae0h (2784)	0	0	0	1	0	1	0	1
b00h (2816)	1	1	1	0	0	1	0	1
b20h (2848)	0	1	1	0	0	1	0	1
b40h (2880)	1	0	1	0	0	1	0	1
b60h (2912)	0	0	1	0	0	1	0	1
b80h (2944)	1	1	0	0	0	1	0	1
ba0h (2976)	0	1	0	0	0	1	0	1
bc0h (3008)	1	0	0	0	0	1	0	1
be0h (3040)	0	0	0	0	0	1	0	1
c00h (3072)	1	1	1	1	1	0	0	1
c20h (3104)	0	1	1	1	1	0	0	1

Hex (Decimal)	1	2	3	4	5	6	7	8
c40h (3136)	1	0	1	1	1	0	0	1
c60h (3168)	0	0	1	1	1	0	0	1
c80h (3200)	1	1	0	1	1	0	0	1
ca0h (3232)	0	1	0	1	1	0	0	1
cc0h (3264)	1	0	0	1	1	0	0	1
ce0h (3296)	0	0	0	1	1	0	0	1
d00h (3328)	1	1	1	0	1	0	0	1
d20h (3360)	0	1	1	0	1	0	0	1
d40h (3392)	1	0	1	0	1	0	0	1
d60h (3424)	0	0	1	0	1	0	0	1
d80h (3456)	1	1	0	0	1	0	0	1
da0h (3488)	0	1	0	0	1	0	0	1
dc0h (3520)	1	0	0	0	1	0	0	1
de0h (3552)	0	0	0	0	1	0	0	1
e00h (3584)	1	1	1	1	0	0	0	1
e20h (3616)	0	1	1	1	0	0	0	1
e40h (3648)	1	0	1	1	0	0	0	1
e60h (3680)	0	0	1	1	0	0	0	1
e80h (3712)	1	1	0	1	0	0	0	1
ea0h (3744)	0	1	0	1	0	0	0	1
ec0h (3776)	1	0	0	1	0	0	0	1
ee0h (3808)	0	0	0	1	0	0	0	1
f00h (3840)	1	1	1	0	0	0	0	1
f20h (3872)	0	1	1	0	0	0	0	1
f40h (3904)	1	0	1	0	0	0	0	1
f60h (3936)	0	0	1	0	0	0	0	1
f80h (3968)	1	1	0	0	0	0	0	1
fa0h (4000)	0	1	0	0	0	0	0	1
fc0h (4032)	1	0	0	0	0	0	0	1
fe0h (4064)	0	0	0	0	0	0	0	1
1000h (4096)	1	1	1	1	1	1	1	0
1020h (4128)	0	1	1	1	1	1	1	0
1040h (4160)	1	0	1	1	1	1	1	0
1060h (4192)	0	0	1	1	1	1	1	0

Hex (Decimal)	1	2	3	4	5	6	7	8
1080h (4224)	1	1	0	1	1	1	1	0
10a0h (4256)	0	1	0	1	1	1	1	0
10c0h (4288)	1	0	0	1	1	1	1	0
10e0h (4320)	0	0	0	1	1	1	1	0
1100h (4352)	1	1	1	0	1	1	1	0
1120h (4384)	0	1	1	0	1	1	1	0
1140h (4416)	1	0	1	0	1	1	1	0
1160h (4448)	0	0	1	0	1	1	1	0
1180h (4480)	1	1	0	0	1	1	1	0
11a0h (4512)	0	1	0	0	1	1	1	0
11c0h (4544)	1	0	0	0	1	1	1	0
11e0h (4576)	0	0	0	0	1	1	1	0
1200h (4608)	1	1	1	1	0	1	1	0
1220h (4640)	0	1	1	1	0	1	1	0
1240h (4672)	1	0	1	1	0	1	1	0
1260h (4704)	0	0	1	1	0	1	1	0
1280h (4736)	1	1	0	1	0	1	1	0
12a0h (4768)	0	1	0	1	0	1	1	0
12c0h (4800)	1	0	0	1	0	1	1	0
12e0h (4832)	0	0	0	1	0	1	1	0
1300h (4864)	1	1	1	0	0	1	1	0
1320h (4896)	0	1	1	0	0	1	1	0
1340h (4928)	1	0	1	0	0	1	1	0
1360h (4960)	0	0	1	0	0	1	1	0
1380h (4992)	1	1	0	0	0	1	1	0
13a0h (5024)	0	1	0	0	0	1	1	0
13c0h (5056)	1	0	0	0	0	1	1	0
13e0h (5088)	0	0	0	0	0	1	1	0
1400h (5120)	1	1	1	1	1	0	1	0
1420h (5152)	0	1	1	1	1	0	1	0
1440h (5184)	1	0	1	1	1	0	1	0
1460h (5216)	0	0	1	1	1	0	1	0
1480h (5248)	1	1	0	1	1	0	1	0
14a0h (5280)	0	1	0	1	1	0	1	0

Hex (Decimal)	1	2	3	4	5	6	7	8
14c0h (5312)	1	0	0	1	1	0	1	0
14e0h (5344)	0	0	0	1	1	0	1	0
1500h (5376)	1	1	1	0	1	0	1	0
1520h (5408)	0	1	1	0	1	0	1	0
1540h (5440)	1	0	1	0	1	0	1	0
1560h (5472)	0	0	1	0	1	0	1	0
1580h (5504)	1	1	0	0	1	0	1	0
15a0h (5536)	0	1	0	0	1	0	1	0
15c0h (5568)	1	0	0	0	1	0	1	0
15e0h (5600)	0	0	0	0	1	0	1	0
1600h (5632)	1	1	1	1	0	0	1	0
1620h (5664)	0	1	1	1	0	0	1	0
1640h (5696)	1	0	1	1	0	0	1	0
1660h (5728)	0	0	1	1	0	0	1	0
1680h (5760)	1	1	0	1	0	0	1	0
16a0h (5792)	0	1	0	1	0	0	1	0
16c0h (5824)	1	0	0	1	0	0	1	0
16e0h (5856)	0	0	0	1	0	0	1	0
1700h (5888)	1	1	1	0	0	0	1	0
1720h (5920)	0	1	1	0	0	0	1	0
1740h (5952)	1	0	1	0	0	0	1	0
1760h (5984)	0	0	1	0	0	0	1	0
1780h (6016)	1	1	0	0	0	0	1	0
17a0h (6048)	0	1	0	0	0	0	1	0
17c0h (6080)	1	0	0	0	0	0	1	0
17e0h (6112)	0	0	0	0	0	0	1	0
1800h (6144)	1	1	1	1	1	1	0	0
1820h (6176)	0	1	1	1	1	1	0	0
1840h (6208)	1	0	1	1	1	1	0	0
1860h (6240)	0	0	1	1	1	1	0	0
1880h (6272)	1	1	0	1	1	1	0	0
18a0h (6304)	0	1	0	1	1	1	0	0
18c0h (6336)	1	0	0	1	1	1	0	0
18e0h (6368)	0	0	0	1	1	1	0	0





# Appendix B

# 16C864 UART

# Data Sheet

[View from CD](#)

[Download from web](#)

